

Report

KAP – II – FS6 Improving the Protection of Public Assets

# Coastal Monitoring Benchmark Network

**Prepared for the Office of Te Beretitenti, Government of Kiribati (Client)**

**By Beca International Consultants Ltd (Beca)**

14 February 2011

© Beca 2011 (unless Beca has expressly agreed otherwise with the Client in writing).

This report has been prepared by Beca on the specific instructions of our Client. It is solely for our Client's use for the purpose for which it is intended in accordance with the agreed scope of work. Any use or reliance by any person contrary to the above, to which Beca has not given its prior written consent, is at that person's own risk.



## Revision History

Revision N°	Prepared By	Description	Date
A	Marc Jaspers	Final submitted to Client	February 2011

## Document Acceptance

Action	Name	Signed	Date
Prepared by	Marc Jaspers		23/02/2011
Reviewed by	Neil Gunn		23/2/11
Approved by	Richard Frankland		23/2/11
on behalf of	Beca International Consultants Ltd		

## Table of Contents

<b>1</b>	<b>Introduction</b> .....	<b>1</b>
<b>2</b>	<b>Executive Summary</b> .....	<b>1</b>
2.1	Undertake Review .....	1
2.2	Review existing benchmarks .....	1
2.3	Provide construction specifications .....	2
2.4	Provide new survey equipment .....	2
2.5	Assist LMD .....	2
2.6	Lead training.....	2
2.7	Undertake Levelling.....	2
2.8	Undertake a full check.....	2
<b>3</b>	<b>Time Line</b> .....	<b>3</b>
3.1	Site Visit September 2010.....	3
3.2	Purchase of Survey Equipment.....	3
3.3	Training Preparation.....	3
3.4	Site Visit October 2010.....	3
<b>4</b>	<b>Accuracies &amp; Methodology</b> .....	<b>4</b>
<b>5</b>	<b>Datum Investigation</b> .....	<b>5</b>
<b>6</b>	<b>Summary of Results</b> .....	<b>6</b>
6.1	Summary of level loop miscloses .....	7

## Appendices

**Appendix 1 - Terms of Reference**

**Appendix 2 - NIWA Draft Report – Tarawa Survey Datums**

**Appendix 3 - Letter of Delivery for Equipment Purchased**

**Appendix 4 - Benchmark Specification**

**Appendix 5 - Extract from South Pacific Sea Level & Climate Monitoring Project**

**Appendix 6 - Extract from GPS Control Survey, South Tarawa**

**Appendix 7 - Digital Level - Downloading Procedure**

**Appendix 8 - Map Series (Sheets 1-11) Benchmark Locations**

## 1 Introduction

The Kiribati Adaptation Project (Phase II) – Improving the Protection of Public Assets (KAPII) includes the design and construction of sea walls in South Tarawa as climate change adaptation options. Accurate levels were required in the locations of proposed construction works in order to confirm the heights of the completed sea walls (in terms of sea level) were appropriate. In the absence of a network of benchmarks with accurate levels, Beca was commissioned to assist the Land Management Division (LMD) of the Government of Kiribati to install and survey a series of accurate benchmarks from Betio to Bonriki.

Included in the scope of the survey work was the investigation into discrepancies between the two known level datums on the island: SEAFRAME and the University of Hawaii Datum (UoH). Also included was an element of training and capacity building for staff in the LMD and the purchase and supply of a digital level and associated survey equipment.

A significant amount of related survey work has been undertaken in Tarawa in relation to sea level monitoring. Two specific projects which are relevant to this work are a GPS control survey undertaken by the Secretariat of the Pacific Applied Geoscience Commission (SOPAC) refer Appendix 6, and more recently the South Pacific Sea Level and Climate Monitoring Project (SPSLCMP) which is being undertaken by various government bodies including Geoscience Australia, refer Appendix 5.

The benchmarks installed by the SPSLCMP have provided the basis for levels for this project.

## 2 Executive Summary

The Terms of Reference for this work (refer Appendix 1) noted the following requirements. Our successful completion of these tasks is summarised below (with the wording from the TOR shown in italics).

### 2.1 Undertake Review

*Undertake a review of the existing datum's in consultation with all of the relevant Government of Kiribati (GoK) bodies and NIWA to recommend the most sustainable datum for future use.*

Prior to commencing the work in Tarawa we discussed this aspect of the work with NIWA (Doug Ramsay), and outlined our proposed course of action, i.e. observe several tide levels, tie these levels into the work undertaken by the SPSLCMP project and conclude which of the two datums that the project is related to.

We have concluded, refer Section 5 below, (in agreement with NIWA's findings) that the SPSLCMP work is in terms of SEAFRAME, and not as they indicate, in terms of UoH Datum. Refer Appendix 2 – NIWA Draft Report – Tarawa Survey Datums.

### 2.2 Review Existing Benchmarks

*Undertake a review of the existing benchmarks and confirm the locations for at least 15 new benchmarks.*

The review was undertaken by Beca's Senior Surveyor (Neil Gunn) on his visit to Tarawa, and the locations of proposed marks were identified at that time. A total of 31 new benchmarks have been constructed and surveyed as part of this work.

### **2.3 Provide Construction Specifications**

*Provide construction specifications for robust permanent benchmarks and any specific materials that are not readily available in Tarawa, such as mushroom plaques.*

Refer Appendix 4 for the specifications provided for the construction of new benchmarks. Twenty brass mushroom plaques were provided to LMD on the visit by Neil Gunn. Beca identified that additional benchmarks should be constructed wherever large concrete structures existed in suitable locations. 25 such marks were constructed using steel pins provided on the second trip by Beca's Surveyor (Marc Jaspers).

### **2.4 Provide New Survey Equipment**

*Provide new survey equipment to Lands Management Division including a digital level, barcode staff, data recorder, reduction & adjustment software.*

Refer Appendix 3 for a list of equipment bought on behalf of LMD and delivered to Tarawa.

### **2.5 Assist LMD**

*Assist LMD with the planning and preparation of the construction of the permanent benchmarks.*

The process of assisting LMD was successfully achieved, and the existing benchmarks are the evidence of this effort. Staff from the KAPII project office assisted with elements of supervision and procurement support during the construction and pouring of concrete.

### **2.6 Lead Training**

*Lead training sessions on the use of the new equipment, associated survey procedures and the software.*

Beca's Surveyor (Marc Jaspers) spent 9 days on Tarawa leading the training sessions which were heavily focussed on the practical elements of the work. The fact that the surveyors from the LMD successfully completed all the fieldwork, including approximately 70% without direct supervision illustrates that the training programme was appropriate and successful.

### **2.7 Undertake Levelling**

*Undertake levelling to transfer heights to the newly constructed benchmarks with the LMD staff*

This was a component of the training programme referred to above.

### **2.8 Undertake a Full Check**

*Undertake a full check and calibration of the benchmark coordinates and heights*

Beca has reviewed the field data, checked and verified the miscloses, and produced the final levels together with plans and photographs of all the benchmark locations.

### **3 Time Line**

#### **3.1 Site Visit September 2010**

Beca's Senior Surveyor (Neil Gunn) travelled to Tarawa in September 2010 to meet with Kautuna Kaitara of the KAPII Project Management Unit (PMU) and representatives of the LMD. The proposed route was reviewed to identify existing survey marks suitable for inclusion in the network and locations for the construction of new benchmarks. Approximate GPS fixes were taken at all the existing and proposed locations. The fieldwork was supported by LMD, with Kataebti Bataua assisting in transport arrangements, and identifying existing survey mark locations.

Prior to the site visit, and in consultation with Romano Reo, the design and construction of brass "mushroom" plaques (to be installed in the new concrete benchmarks) was arranged. Twenty of these plaques were delivered to LMD during this visit.

Upon return to Auckland a set of draft plans were produced using the information collected showing the location of all existing and proposed benchmarks.

Staff of the LMD constructed six new benchmarks (KB1 – KB6) in the agreed locations.

#### **3.2 Purchase of Survey Equipment**

Beca contacted four survey equipment suppliers in Auckland and requested quotations for the purchase of a digital level and associated survey equipment (survey staff and software). Quotations for industry standard brands of survey equipment (Leica, Trimble, Topcon and Sokkia) were received from these suppliers. The Leica and Trimble options appeared to be the best value for money. The LMD's Chief Surveyor (Romano Reo) expressed a preference for the Leica model and, after getting approval in principle from the KAPII PMU, a Leica DNA10 digital level and barcode staff were purchased along with software and associated items such as battery chargers and a levelling base plate. One set of medium range walkie-talkies were also bought for the project at this time.

#### **3.3 Training Preparation**

In preparation for Beca's second trip to Tarawa, the survey equipment was tested on known benchmarks in Auckland and the software reviewed. Brief training notes were developed for use in training the LMD in Tarawa.

#### **3.4 Site Visit October 2010**

Beca's Surveyor (Marc Jaspers) travelled to Tarawa in October 2010. The objectives of the visit were to:

- deliver the new survey equipment,
- inspect the concrete benchmarks constructed by LMD and oversee the installation of new intermediate benchmarks,
- undertake a training programme with surveyors in the LMD and commence levelling fieldwork, and
- investigate and attempt to resolve the apparent discrepancy between the two tidal datums on South Tarawa.

The new survey equipment was formally delivered to KAPII on Wednesday 20<sup>th</sup> October 2010.

A series of practical training workshops were carried out with the LMD survey team. The following eight days (with the exception of Sunday which was dedicated to mark installation) were spent surveying between marks in the network. Marc worked in a supervisory role planning the procedure and answering the questions of the levelling teams. The emphasis at an early stage was for the LMD staff to undertake as much of the survey fieldwork as possible in order for them to become proficient in the use of the equipment. Refer to Appendix 7 for the procedure for data collection and adjustment.

Each day was roughly split in half between the field and office where LMD staff were also trained in the processing of data. A single "loop" (from one mark to the next and back) of about 2km could be completed in a morning and would be processed back in the office that afternoon. This enabled the team to keep the processing and field work progressing at the same speed.

As part of the processing the levelling teams were given several ideas on best practice in regards to the management of both the raw and processed data as a large amount of data was expected.

At the conclusion of Beca's trip approximately 30% of the network had been completed and the LMD team were efficiently undertaking precise levelling fieldwork and data downloading. This was less than anticipated, however the emphasis was placed on ensuring the team were able to operate independently (rather than simply advancing the progress at the cost of proper training).

With regard to the construction of the intermediate benchmarks, the majority of this work was undertaken on Sunday 24<sup>th</sup> October 2010. All the benchmark locations had been previously identified during Beca's visit in September. The LMD team placed an additional 15 intermediate benchmarks throughout the network to break up loops into more manageable lengths, and created additional marks to cover the inevitable future destruction of some of these survey marks.

The final task involved taking several observations of sea levels and relating these to the benchmarks in an attempt to conclude which of the two tide datums were related to the recent work undertaken for the sea level monitoring work by SOPAC.

## **4 Accuracies & Methodology**

Conventional higher order levelling involves a series of closed loops in which each individual level run starts and finishes on the same mark. These loops are built up into larger loops which act as a second form of checking and also generate some confidence as to the ultimate accuracy of the overall levelling. Given the shape of the island of South Tarawa (i.e. a single road along the length of the island) it is not practical to undertake the overall loop. Each individual loop has been joined to the previous loop. Whilst this was adequate, it removes one element of the checking process. It was initially assumed that the airport Aerodrome Reference Point (ARP) mark would provide an accurate level for checking purposes. However, LMD's Chief Surveyor confirmed that the current level for the ARP had been established with GPS methodology and was therefore not accurate enough to act as a check. In addition to this, it was not possible to obtain levelled values for any of the existing marks (eg Betio Causeway) located along the route.

Three benchmarks from the SPSLCMP project were located and confirmed reliable by levelling between them and gaining agreement to within 1mm.

For each loop observed, generally of the order of 1km, the expected misclose (given the equipment being used) was no more than 2 - 3mm. Differences greater than this were rejected and the fieldwork repeated until the misclose was more acceptable.

## 5 Datum Investigation

A 2008 NIWA report investigated the relationship between the University of Hawaii datum (UOH) and the SEAFRAME datum. That report concluded that there is 419mm difference between the two tide gauges i.e. they are datum's based on a different zero point.

*"Our analysis suggests....SEAFRAME Gauge 0 being 419mm below that of the U of H Gauge..."*

*NIWA report May 2008*

The report concluded that the two datums were related to mean sea level as follows;

	Level (UoH)	Level (SEAFRAME)
<b>Mean Sea Level (2007)</b>	1.218m	1.637m

Prior to visiting Tarawa we discussed this issue with Doug Ramsay of NIWA, and noted that our approach to resolving this confusion would involve a pragmatic approach in which we hoped that observations of mean seal level would agree with one of these two datums. It was not within the scope of work to define a new datum. NIWA concurred with our approach.

Beca's Surveyor (Marc Jaspers) undertook the field component of the investigation. The approach is explained below:

- Benchmarks from the SOPAC network (refer Appendix 5) were located and confirmed as reliable by levelling between three of these marks (KIR12, KIR100 and KIR102).
- Observations of high and low tide were taken from KIR12 on 22<sup>nd</sup> October 2010. KIR12 is situated very close to the SEAFRAME tide gauge.
- Relative to KIR12 we observed a mean sea level of 1.73m.
- The following day, at another location, the exercise was repeated and a value of 1.68m.
- Given the relative coarse approach to our observations (i.e. measurements taken over a 12 hour time period) the estimated accuracy of the results is no better than +/- 0.1m
- Our conclusion is that the SOPAC network of benchmarks is in terms of the SEAFRAME tide gauge. In this matter we therefore agree with the NIWA report.

## 6 Summary of Results

Refer to map series 1-11 (Appendix 8) for the locations of these marks.

We have taken photos of each benchmark location, labelled the image with the benchmark name (for clarity), zipped these up and emailed to the PMU.

Name	Reduced Level	Comments
<b>SOPAC Benchmarks</b>		
KIR 12	4.220	Project Plaque - Origin of levels
KIR 100	3.832	Refer map
KIR 102	4.010	Refer map
<b>New Concrete Benchmarks (with Plaque)</b>		
KB1	3.717	In Betio - approx 150m north of junction
KB2	3.607	North side of road
KB3	3.428	Eastern end of Ambo-Taborio Causeway
KB4	3.418	Adjacent Bonriki police station
KB5	3.688	North West corner of road junction
KB6	3.930	At entrance to Taiwan embassy
<b>Existing Benchmarks - with Updated Levels</b>		
Betio Causeway	6.165	in bridge abutment
UT 179A	4.145	mark in concrete collar
UT 214B	3.626	mark in concrete collar
UT 348	3.482	mark in concrete collar
UT 350	3.683	mark in concrete collar
<b>Bonriki Airport ARP &amp; Runway Threshold Marks</b>		
Airport ARP	3.077	In grass island opposite terminal
Airport TH09	3.983	At western end of runway
Airport TH27	4.641	At eastern end of runway
<b>Intermediate Marks Established (Pin Drilled into Concrete Structure)</b>		
OP 100	5.043	In concrete slab west of Betio Pillar
Pin 100	4.536	In same slab as OP100
Pin 102	3.734	In concrete slab in walkway to church
Pin 103	3.559	In entrance to Parliament
Pin 104	4.556	At entrance to school
Pin 105	3.842	In concrete slab (near coast)
Pin 106	4.062	In circular concrete manhole chamber
Pin 107	3.657	In concrete slab at Temaikau junction
Pin 200	3.770	In base of concrete block wall
Pin 201	3.555	In concrete kerb – church entrance
Pin 201A	4.516	?
Pin 204	3.731	In concrete kerb
Pin 205	3.886	In concrete footing – petrol station
Pin 206	4.278	In base of small concrete structure

Pin 207	2.995	In concrete base of sluice valve
Pin 208	3.976	In concrete slab at shop entrance
Pin 209	3.902	At entrance to Moroni High School
Pin 210	2.908	In concrete base near entrance to hotel
Pin 211	3.971	In top of low concrete sea wall
Pin 212	3.522	In concrete slab
Pin 213	3.504	In circular concrete manhole chamber
Pin 214	3.921	At base of concrete plaque
Pin 215	4.758	In corner of concrete slab

## 6.1 Summary of Level Loop Miscloses

Loop Description	Misclose (mm)
Tide Gauge – KIR MH	+0.6
KIR MH – KB1	+0.2
KB1 – PIN 201	+2.0
PIN 201 – PIN 100	-1.9
PIN 100 – Betio Causeway	-0.3
Betio Causeway – PIN 201A	-0.3
PIN 201A – UT 179A	+1.6
UT 179A – PIN 204	-0.7
PIN 204 – UT 348	-1.0
UT 348 – PIN 102	+0.6
PIN 102 – PIN 205	+2.3
PIN 205 – KB2	+1.8
KB2 – PIN 206	+1.5
PIN 206 – PIN 103	-0.5
PIN 103 – PIN 207	-0.6
PIN 207 – KB3	-0.4
KB3 – PIN 208	-0.3
PIN 208 – PIN 104	-0.4
PIN 104 – PIN 209	-0.2
PIN 209 – PIN 210	-0.3
PIN 210 – PIN 105	-0.3
PIN 105 – PIN 211	-2.6
PIN 211 – UT 214B	+0.2
UT 214B – PIN 213	+0.9
PIN 213 – PIN 212	-0.5

Loop Description	Misclose (mm)
PIN 212 – PIN 106	+0.2
PIN 206 – PIN 214	+1.8
PIN 214 – PIN 107	-1.4
PIN107 – PIN 217 – KB4 – TH27 – KB5 – KB6 – PIN107	+0.4
KB4 – TH09	+0.8

Appendix 1

## Terms of Reference



*Country:* REPUBLIC OF KIRIBATI

*Project Name* KIRIBATI ADAPTATION PROJECT - PHASE II

*Trust Fund #* GEF TF056267

*Title of Consulting Services*  
IMPROVING THE PROTECTION OF PUBLIC ASSETS

**CONTRACT FOR CONSULTANTS' SERVICES**

**Contract Number: KAP II FSS0942-FS-06/2009**  
**CONTRACT ADDENDUM # 1**

**JUNE 2010.**

*Am*

## **SECTION III – COASTAL MONITORING BENCHMARK NETWORK – TERMS OF REFERENCE**

### **SERVICES REQUIRED**

Establishing a coastal monitoring benchmark network for South Tarawa.

### **PROJECT BACKGROUND**

There is currently no formal network of benchmarks in South Tarawa to which construction heights can be calibrated. This is of particular importance to coastal management which requires the construction of coastal defences to be built to specific design heights to prevent wave overtopping. It is anticipated that a coastal benchmark network could be installed under this TOR to establish a reliable datum for the length of South Tarawa.

### **DESCRIPTION OF SERVICES REQUIRED**

1. **Coastal Monitoring Benchmark Network.** The consultant will assist the Land Management Division in the installation and survey of coastal monitoring benchmarks from Betio Town to Bonriki Airport. Survey Benchmarks should be constructed every 2 kilometres along the road to the airport, in locations where their stability is maximised, and also adjacent to areas proposed for seawall construction under this project. The consultant shall:
  - a) Undertake a review of the existing datum's in consultation with all of the relevant GoK bodies and NIWA to recommend the most sustainable datum for future use.
  - b) Undertake a review of the existing benchmarks and confirm the locations for at least 15 new benchmarks.
  - b) Provide construction specifications for robust permanent benchmarks and any specific materials that are not readily available in Tarawa such as stainless steel identification markers.
  - c) Provide new survey equipment to Lands Management Division including a digital level, barcode staff, data recorder, reduction and adjustment software.
  - d) Assist the Land Management Division with the planning and preparation of the construction of the permanent benchmarks.
  - e) Lead training sessions on the use of the new equipment, associated survey process and the software.
  - f) Undertake levelling to transfer heights to the newly constructed benchmarks with the Land Management Staff.
  - g) Undertake a full check and calibration of the benchmark coordinates and heights.
2. The consultant will work closely with the KAPII PMU staff to ensure that the benchmarks are located near the proposed coastal protection construction sites.
3. The consultant will undertake a Coastal Monitoring Benchmark Network Report which will confirm the final levels and photographic record of the benchmarks. A draft report will be distributed in hard copy to all members of the FMC and any other relevant GoK agencies for comment. The draft report should be delivered at such a time that allows for comments and if necessary clarification by the end users before the final report is delivered. 10 hard copies of the final report will be provided by the consultant for distribution and circulation around the GoK agencies to ensure that the location and relevance of the benchmarks is widely known.

### **OUTPUTS**

4. *Coastal Monitoring Benchmark Network:*

- a) **Construction Specifications** and associated documentation for the construction the permanent benchmarks.
- b) **15 Permanent Benchmarks** constructed, levelled and corrected to the selected standard datum.
- c) **Coastal Monitoring Benchmark Network Report** as specified in para. 3.

**MILESTONES, DELIVERY PLAN AND PROJECT TIMEFRAME**

No.	Activity	Subsidiary Milestone	Principal Milestone
4	<i>Coastal Monitoring Benchmark Network</i>		
4.1	Construction Specifications and Associated Documentation	Submission of Draft Construction Specifications and the associated documentation to construct the permanent benchmarks	Completion and Approval of the Construction Specifications and the associated documentation to construct the permanent benchmarks
4.2	Construction and Levelling of the Coastal Monitoring Benchmark Network	Completion of benchmark construction at least 15 sites	Completion of Levelling and correction of all of the benchmarks
4.3	Coastal Monitoring Benchmark Network Report	Draft Coastal Monitoring Benchmark Network Report	Completion and approval of Coastal Monitoring Benchmark Network Report

Appendix 2

## NIWA Draft Report - Tarawa Survey Datums

## Tarawa Survey Datums: Relationship between University of Hawaii Tide Gauge 0, Mean Sea Level and SEAFRAME Tide Gauge 0.

**Draft for discussion  
May 2008**

### Introduction

This note has been produced to correct what we believe is an error in the assumption in the relationship between the University of Hawaii (U of H) Tide Staff 0 and SEAFRAME Tide Gauge 0 at Betio in Tarawa. It has been assumed by the South Pacific Sea Level and Climate Monitoring Project (SPSLCS) that Gauge 0 for the SEAFRAME gauge installed by the project is the same as Gauge 0 of the University of Hawaii Tide Gauge installed at Betio between May 1974 and December 1983 (Annex 1).

Our analysis suggests that this is not the case with the SEAFRAME Gauge 0 being 419 mm below that of the U of H Gauge 0, as summarised in Figure 1.

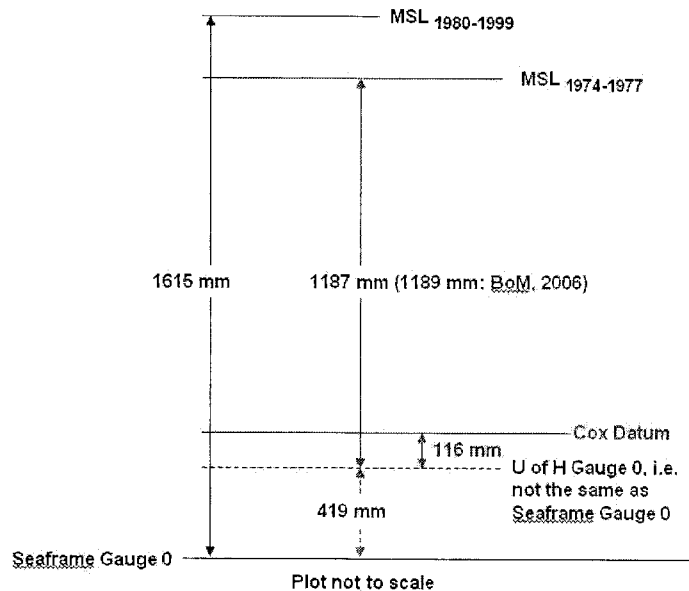

**Figure 1:** Suggested revised relationship between datums used on Tarawa.<sup>1</sup>

### Discussion

On Tarawa there are four different tide gauge records available extending back to May 1974 (Table 1) and Figure 2. The present SEAFRAME facility has been in place since 1993, with gauge 0 of this facility used as the reference level for tide predictions and sea-level recordings.

BoM (2006), summarised in Annex 1, state that: “Sea levels in the NTC data are normally reported relative to “Chart Datum” (CD), thus enabling users to relate the NTC data directly to depth soundings

<sup>1</sup> We have included Cox datum for completeness based on the information provided in He (2001) but have not checked the accuracy of the information provided by He in relation to this datum.

shown on marine charts..... Unfortunately, at Tarawa the original benchmark used for the marine surveys is unrecoverable..... In the absence of a known CD, NTC has chosen to refer sea level to the older UH datum, or "Tide Staff Zero". With this choice, the Mean Sea Level of either data set is close (though not necessarily identical). Mean Sea Level (MSL)..... is the average recorded level at the gauge over the three and a half year period 1974/1977. The 1974/1977 MSL at Tarawa was 1.189 metres above the UH Tide Staff Zero (and the SEAFRAME zero level).

Our own analysis of the University of Hawaii (Tarawa A) dataset (Ramsay et al, 2008) gave a mean level of the sea of 1.187 m, i.e. almost identical to the earlier University of Hawaii analysis noted above. However, in plotting the four datasets, Figure 2, the Tarawa A dataset appears to be relative to a different datum than the subsequent datasets.

The overlapping portions of the four records were examined and the historical records were adjusted to SEAFRAME gauge Zero (Figure 3). In merging the records it has been assumed that the sea level characteristics from the Bairiki deployment (Tarawa B) are not significantly different to those at the Betio site. However, geographical differences may modify some characteristics of tidal propagation, amplification and wind set-up and set-down to some (probably relatively minor) extent.

**Table 1.** *Sea level records available for Tarawa. The tabulated datum shift for each record based on consideration of the overlapping components of each record, is shown in the last column.*

Name	Location	Start date	Finish date	Datum shift (mm)
Tarawa A	Betio	31 May 1974	31 Dec 1983	+419
Tarawa B	Bairiki	17 May 1983	10 May 1988	+23
Tarawa C	Betio	20 Jan 1988	31 Dec 1997	+23
SEAFRAME (D)	Betio	27 Mar 1993	Ongoing	0

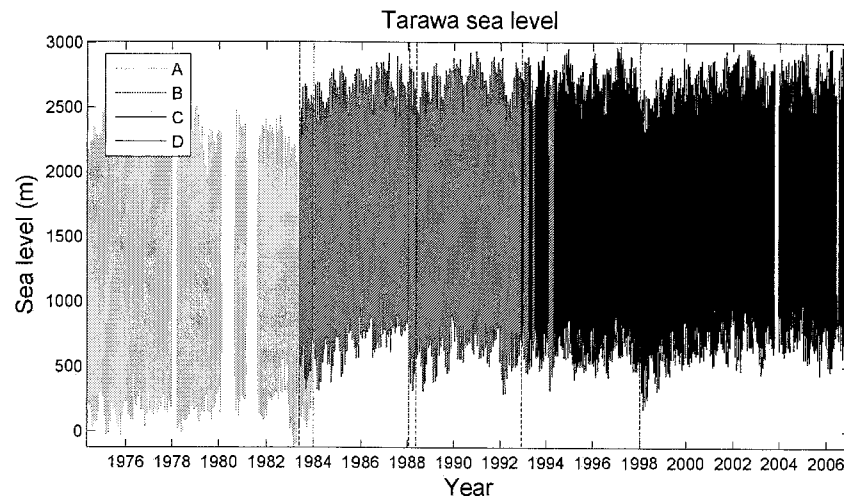

**Figure 2:** *Plot of measured Tarawa sea levels between May 1974 to the present from the four available sea-level records (Table 1).*

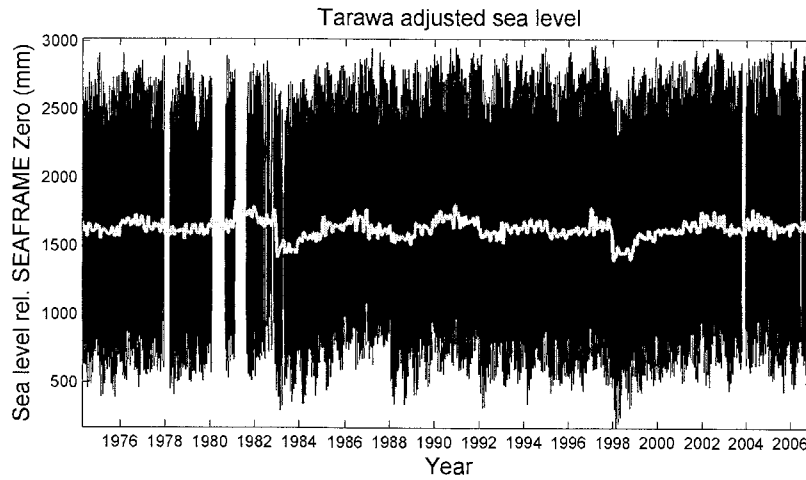

**Figure 3:** *Plot of adjusted raw sea levels taking account of datum shifts note d in Table 1. The yellow line marks mean level of the sea. The datum is SEAFRAME gauge Zero.*

### Conclusions

It is suggested that the U of H Tide Gauge 0 and the SEAFRAME Gauge 0 are not the same datum with the actual relationship as shown in Figure 1. This has implications for previous assessments of coastal inundation that have utilised the SEAFRAME data.

The conversion between the datums can be summarised as

- To convert from SEAFRAME Gauge 0 datum to U of H Gauge 0 datum **subtract 0.419 m.**
- To convert from U of H Gauge 0 datum to SEAFRAME Gauge 0 datum **add 0.419 m.**

The following table summarises some key levels relative to both SEAFRAME Gauge 0 and U of H Gauge 0.

**Table 2.** *Summary of some key levels relative to the UK and SEAFRAME Gauge 0 datums.*

Sea level	Level (mm U of H)	Level (mm SEAFRAME)
Mean sea level (1974-1977)	1187 mm (1189 mm: BoM 2006)	1606 mm
Mean sea level (1980-1999) IPCC sea-level projection reference datum	1196 mm	1615 mm
Mean sea level (2007)	1218 mm	1637 mm

## References

Bureau of Meteorology (2006). Sea level and climate: Their present state. Kiribati. June 2006.

He, C. (2001). Assessment of the Vulnerability of Bairiki and Bikenibeu, South Tarawa, Kiribati to accelerated sea-level rise. SOPAC Technical Report 322.

Ramsay, D.L., Stephens, S., Gorman, R., Oldman, J., Bell, R. (2008). Kiribati Adaptation Programme: Phase II: Information for climate risk management. Sea levels, waves, run-up and overtopping. NIWA Draft Client Report HAM2008-022, February 2008.

## Contact details

Dr Scott Stephens & Doug Ramsay

National Institute of Water & Atmospheric Research Ltd (NIWA)

PO Box 11115, Hamilton, New Zealand

Email: [d.ramsay@niwa.co.nz](mailto:d.ramsay@niwa.co.nz) Tel: +64 7 859 1894

Appendix 3

## Letter of Delivery for Equipment Purchased



132 Vincent Street  
PO Box 6345, Auckland 1141, New Zealand  
T: +64 9 300 9000 // F: +64 9 300 9300  
E: info@beca.com // www.beca.com

Project Coordinator  
Kiribati Adaptation Project II  
Office of Te Beretitenti  
PO Box 462, Bairiki Tarawa  
Republic of Kiribati

18 October 2010

**Attention: Mr Kautuna Kaitara**

Dear Kautuna

**Supply of Survey Equipment for KAP II Project**

Within the extension of work recently approved for the above project, for survey work relating to benchmarks on Tarawa there is a lump sum budget for purchase of survey equipment amounting to AU\$8k. After discussions with Mr Romano Reo, the Kiribati Chief Surveyor, and also yourself, we have purchased on your behalf a digital level and other ancillary items (listed below). Marc Jaspers has brought these items with him and the purpose of this letter is to record the formal delivery of these items. We note that the equipment supplied does not complete the likely purchases since there is a small residual amount of budget left which is yet to be allocated.

The complete list of equipment supplied is as follows, and a copy of the invoice from the supplier is attached.

- Leica DNA10 Digital Level, SN:341632
- Leica GEB121 Battery x 2
- Leica GKL112 Battery Charging Plate
- Leica Geo Office Software on CD ROM, SN:10177932
- Leica Geo Office Protection Key USB single use Licence
- Leica Geo Office Level Data Processing
- Bar Coded Levelling Staff GKNL4M
- Data Transfer cable GEV 189

Yours faithfully

**Neil Gunn**  
Technical Director – Beca

**Beca Infrastructure Ltd**

Direct Dial: +64-9-300 9249  
Email: marc.jaspers@beca.com

On behalf of the Government of Kiribati, and the Kiribati Adaptation Project II, I confirm receipt of the survey equipment listed above.

-----  
Mr. Kautuna Kaitara  
Project Coordinator

-----  
Date

Appendix 4

## Benchmark Specification

# Diagrams for Benchmark Construction

1 Natural Ground

2 Stainless steel pin (25mm dia) top 10mm above concrete

3 Bronze identification plaque

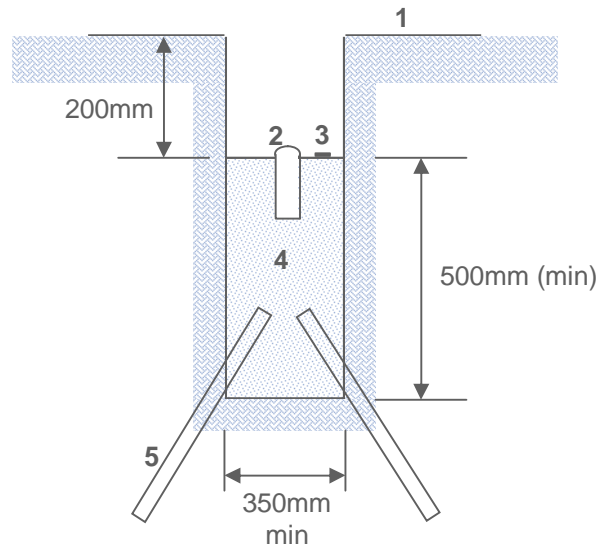

Diagram of benchmark  
(hand digging)

4 Concrete

5 Waratah or re-bar rods 15-20mm dia

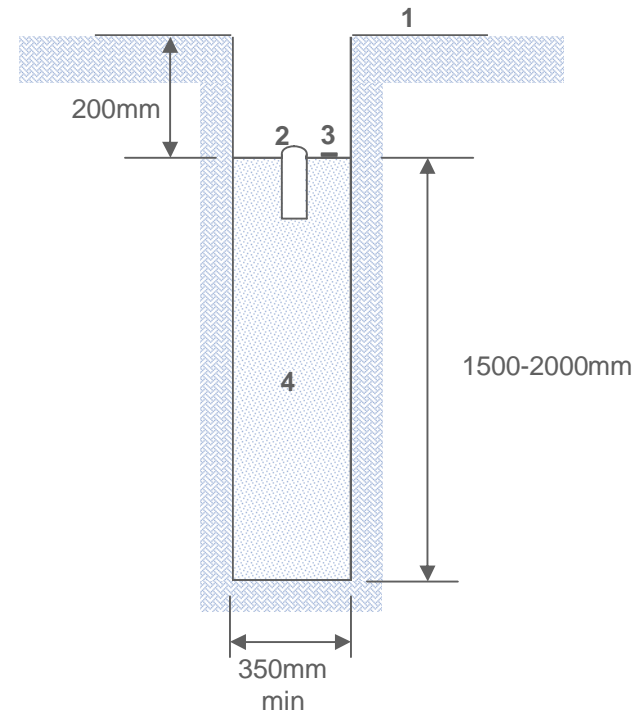

Diagram of benchmark  
(machine drilled)

# Benchmark Construction

---



Stainless Steel pin (25mm dia)

Bronze ID plaque. Note: lettering would be changed for Kiribati project to:

**GEODETIC BENCHMARK**

**BM NO:**



Geodetic Benchmark example construction showing the stainless steel pin and identification plaque

Appendix 5

**Extract from South Pacific  
Sea Level & Climate  
Monitoring Project**



**Australian Government**  

---

**Geoscience Australia**

South Pacific Sea Level and Climate Monitoring  
Project (SPSLCMP)

**Survey Report**

EDM Height Traversing  
Levelling Survey

**KIRIBATI**

**February / March 2009**

This project is sponsored by the Australian Agency for International Development (AusAID), managed by the Bureau of Meteorology (BOM) and supported by the National Geospatial Reference Systems Project, Geospatial Earth Monitoring Division, GEOSCIENCE AUSTRALIA.

Geocat # 69399



© Commonwealth of Australia (Geoscience Australia) 2009. This material is released under the Creative Commons [Attribution 2.5 Australia](http://creativecommons.org/licenses/by/2.5/au/) Licence.  
<http://creativecommons.org/licenses/by/2.5/au/>

## Table of Contents

Introduction .....	3
The Survey .....	3
Bench Mark Locality Map .....	4
The Kiribati Datum.....	5
Equipment .....	5
Method .....	5
Survey Support.....	6
Issues .....	6
Description of Marks .....	7
Table of Results for 2009 and Comparisons between 2007 and 2009.....	8
Combined Comparisons 1992 to 2009 .....	9
2009 Reduced Levels.....	10
Time Series of Bench Mark movement relative to the Fixed Deep driven Bench Mark – KIR 1.....	11
Deep driven BM and TBM's Locality Diagrams .....	15
KIRIBM and KIRI Reference Mark Locality Diagrams .....	26



## Introduction

This report outlines the level survey completed during the visit to Betio Island, the Republic of Kiribati in February / March 2009.

Personnel: Steve Yates – Surveyor - **GEOSCIENCE AUSTRALIA**  
Andrick Lal – Surveyor - **SOPAC**

This is the third EDM Height Traversing levelling survey of the deep driven bench mark array in the Republic of Kiribati. These surveys follow the nine previous surveys from 1992 to 2004 undertaken by the National Tidal Centre (NTC) using the Precise Differential Levelling technique.

## The Survey

The EDM Height Traversing level survey was carried out between the 6 deep driven BM's:

**KIR 1**

**KIR 2**

**KIR 3**

**KIR 46**

**KIR 47**

**KIR 49**

Included in the survey was the CGPS Station bench mark, **KIRIBM** and the three Reference Marks **RM1, RM2 and RM3**, the Project Plaque point **KIR12** and SEAFRAME Sensor Bench Mark **KIR13** at the Tide Gauge, Holding Marks **KIR39, KIR44, KIR100, KIR101, KIR102, KIR106** (replacement for KIR103), **KIR104, and KIR105**.

When locating the Deep driven Bench Marks prior to the survey it was found that BM KIR49 (located outside the Police Marine Workshop) had been buried under an extension of the concrete driveway and not accessible. With the assistance of the Marine Police, a 300mm diameter hole was chiselled away to expose the BM below the concrete and a valve box with lid cemented in place. All other deep driven bench marks were located and found undisturbed and in good order.

A new permanent holding mark KIR106 was established to replace KIR103 which was



destroyed after the 2007 survey. KIR106 is a domed stainless steel bolt drilled in concrete and glued in place with quality epoxy resin.

The EDM Height Traversing levelling technique was performed to the Class L2A, as per the Inter-Government Committee on Surveying and Mapping (ICSM), Standards and Practices for Control Surveys, SP1, Ver. 1.5, May 2002.

After reduction an internal precision of  $1\text{mm} \sqrt{K}$  or better was achieved, where K is levelled distance in kilometres. Project Specification for precision is  $2\text{mm} \sqrt{K}$

## Bench Mark Locality Map



## The Kiribati Datum

**KIR 1** is the adopted reference point for the coastal array.

Reduction of the data was calculated holding **KIR 1** fixed at 3.5334 metres Tide Gauge Zero (TGZ), University of Hawaii - the value NTC derived for KIR 1 by adopting the TGZ height (RL = 4.027) of bench mark UT 8 for the initial 1992 survey. The bench mark UT 8 has since been destroyed.

## Equipment

LEICA Total Station Model TCA2003 (S/N 440883).

LEICA Precision Prisms GPH1P (2).

LEICA Rigid Tripod.

Stainless Steel Target Poles supported by LEICA telescopic Bi-Poles (2).

LEICA Cast Iron Change Plates (2).

KESTRAL 4000 Pocket Weather Tracker

## Method

**“Leap-Frog” EDM-Height-Traversing:** "Leap-Frog" EDM-Height-Traversing involves the one target remaining at a particular change point for both sightings. To avoid the possibility of the target being placed on a different point the target is not moved between the back-sight and foresight. Two target/reflectors are employed (on reflector rods with struts). As in spirit levelling, it is imperative that the electronic tacheometer (total station) is set up in the middle between the two reflectors. Recorded are the height differences (between the instrument's trunnion axis and the reflector) that are computed by the electronic tacheometers. In consequence, the ambient temperature and pressure must be input into the instrument since the slope distances must be corrected for temperature and pressure (first velocity correction) on-line. See Rüeger & Brunner (1982) and *The Canadian Surveyor*, 36(1): 69-87.

***All observations were recorded digitally.***

Reduction of the digital data was computed by the Geoscience Australia's levelling program "leveling1.exe". This program computes the height difference between the two reflectors at any one set-up. Results can also be gained with the EDM Height Traversing method by using a single set-up / single rod configuration. To achieve height differences



when using this single rod configuration, a simple comment line is added, indicating this is the case before running the program.

This “single set-up / single rod” configuration is particularly useful when levelling between bench marks which are close together e.g. between the Project Plaque BM and the SEAFRAME Sensor BM.

All levelling bays started and finished with the same reflector and reflector rod, i.e. an even number of setups when the two reflector rod configuration was used – this eliminates any reflector rod zero error.

Atmospheric readings were obtained using a KESTRAL 4000 Pocket Weather Tracker. These atmospheric readings were recorded manually onto the Kiribati Levelling Booking Sheets and entered into the Total Station prior to each level run and approximately every hour thereafter or when ever an obvious change in weather conditions was observed.

## Survey Support

The new Director of the Kiribati Meteorological Service, Mr. Tareti Kireua and his staff Romano Reo and Boata Iabeta, from the Land Management Division provided valuable support during our visit. A special mention to Boata Iabeta, Field Surveyor, for collecting and providing secure storage for all our survey equipment prior to our arrival.

Due to work commitments in the Land Management Division, Boata Iabeta was unable to assistance the survey team on this visit.

Other personnel consulted during the visit:

Ms. Anne Quinane – Australian High Commissioner.

Ms. Meria Russell – AusAid Program Manager.

## Issues

Only one point worth mentioning – the condition of the security fence (especially the south west corner) around the Weather Office is a potential point of unauthorised access and should be inspected regularly.



## Description of Marks

### BETIO ISLAND, REPUBLIC OF KIRIBATI

**KIR 1** is the bench mark held fixed with an **RL = 3.53340 metres**

The height of **KIR 1** was derived by NTC by adopting the TGZ height for the 1992 levelling survey of the University of Hawaii's bench mark **UT 8**.

UT8 Reduced Level = 4.027 metres TGZ.

UT 8 is now destroyed.

Bench Marks:

**KIR 1, KIR 2, KIR 3, KIR 46, KIR 47, and KIR 49** are all Deep Driven BM's.

Point:

**KIR 13** is the SEAFRAME Sensor Bench Mark

**KIR 12** is the Project Plaque point

**KIRIBM** is the Reference Bench Mark for the CGPS Pillar.

**RM1, RM2** and **RM3** are the Reference Monitoring Marks for the CGPS Pillar.

**KIR39, KIR44, KIR100, KIR101, KIR102, KIR104, KIR105** and **KIR106** are all permanent stainless steel bolt holding marks, drilled in concrete and glued in place.



## Table of Results for 2009 and Comparisons between 2007 and 2009

### KIRIBATI 2009 - EDM Height Traversing Levelling Comparison 2007 - 2009 and Table of Results

KIR 1 - Adopted fixed height (TGZ) 3.53340

FROM	TO	Levelled Height Difference	Reduced Level 2009	Misclose (mm)	Distance (Km)	1mm√K	Reduced Level 2007	Difference (m) 2007 - 2009
KIR 1	KIR 102	0.47630	4.00970	0.189	0.051	0.226	4.02185	0.01215
KIR 102	KIR 100	-0.17707	3.83263	-0.034	0.056	0.237	3.83306	0.00043
KIR 100	KIR 39	0.24629	4.07892	0.164	0.197	0.444	4.07867	-0.00025
KIR 39	KIR 101	0.06455	4.14348	-0.277	0.203	0.451	4.14362	0.00015
KIR 101	KIR 49	-0.12062	4.02285	0.060	0.147	0.383	4.02296	0.00011
KIR 49	KIR 12	0.19706	4.21991	0.205	0.173	0.416	4.22020	0.00029
KIR 12	KIR 13	0.41213	4.63204	-0.025	0.012	0.110	4.63078	-0.00126
KIR 1	KIR 102	0.47630	4.00970	0.189	0.051	0.226	4.02185	0.01215
KIR 102	KIR 46	-0.63064	3.37906	-0.029	0.151	0.389	3.37949	0.00043
KIR 46	KIR 106	0.42377	3.80283	0.386	0.146	0.382	<i>New mark established in 2009</i>	
KIR 106	KIR 104	-0.12972	3.67311	0.186	0.202	0.449	3.67264	-0.00047
KIR 104	KIR 2	-0.48963	3.18348	-0.165	0.106	0.326	3.18303	-0.00045
KIR 104	KIR 44	-0.05153	3.62158	0.361	0.187	0.432	3.62292	0.00134
KIR 44	KIR 47	-0.32648	3.29509	-0.112	0.092	0.303	3.29410	-0.00099
KIR 47	KIR 105	0.52975	3.82484	0.383	0.166	0.407	3.82427	-0.00057
KIR 105	KIR 3	-0.26028	3.56456	-0.255	0.199	0.446	3.56405	-0.00051
KIR 3	KIRIBM	0.84793	4.41250	-0.077	0.023	0.152	4.41191	-0.00059

An internal precision of 1mm√K was achieved for all bays levelled - the Project Specification is 2mm√K



## Combined Comparisons 1992 to 2009

### KIRIBATI - Comparison of RL's for Precise Differential Levelling (1992 - 2006) and EDM Height Traversing (2006 - 2009)

YEAR	MARK								
	KIR1	KIR2	KIR3	KIR12	KIR13	KIR46	KIR47	KIR49	KIRIBM
1992	3.5334	3.1835	3.5657	4.2176	4.6302				
1994	3.5334	3.1838	3.5655	4.2187	4.6319				
1995	3.5334	3.1845	3.5654	4.2195	4.6331				
1996	3.5334	3.1843	3.5654	4.2191	4.6321				
1997	3.5334	3.1843	3.5657	4.2196	4.6325				
1999	3.5334	3.1844	3.5644	4.2195	4.6324				
2000	3.5334	3.1847	3.5658	4.2195	4.6321				
2002	3.5334	3.1843	3.5648	4.2191	4.6321	3.3782	3.2948	4.0232	4.4124
2004	3.5334	3.1843	3.5653	4.2190	4.6324	3.3788	3.2952	4.0225	4.4130
2006	3.5334	3.1839	3.5662	4.2195	4.6328	3.3788	3.2956	4.0226	4.4139
2006 EDM	3.5334	3.1844	3.5646	4.2193	4.6326	3.3794	3.2953	4.0230	4.4124
2007 EDM	3.5334	3.1830	3.5641	4.2202	4.6308	3.3795	3.2941	4.0230	4.4119
2009 EDM	3.5334	3.1835	3.5646	4.2199	4.6320	3.3791	3.2951	4.0229	4.4125



## 2009 Reduced Levels

### KIRIBATI - 2009 REDUCED LEVELS

Date: February / March 2009

Datum: TGZ (University of Hawaii, Tide Gauge Zero)

POINT #	2009 Levelled Diff Ht.	2009 RL	
<b><i>KIR 1 (fixed)</i></b>	<b><i>0.00000</i></b>	<b><i>3.53340</i></b>	<b><i>(fixed)</i></b>
KIR 102	0.47630	4.00970	
KIR 100	-0.17707	3.83263	
KIR 39	0.24629	4.07892	
KIR 101	0.06455	4.14348	
<b>KIR 49</b>	<b>-0.12062</b>	<b>4.02285</b>	
KIR 12	0.19706	4.21991	
<b>KIR 13</b>	<b>0.41213</b>	<b>4.63204</b>	
<b><i>KIR 1 (fixed)</i></b>	<b><i>0.00000</i></b>	<b><i>3.53340</i></b>	<b><i>(fixed)</i></b>
KIR 102	0.47630	4.00970	
<b>KIR 46</b>	<b>-0.63064</b>	<b>3.37906</b>	
KIR 106	0.42377	3.80283	
KIR 104	-0.12972	3.67311	
<b>KIR 2</b>	<b>-0.48963</b>	<b>3.18348</b>	
KIR 104		3.67311	
KIR 44	-0.05153	3.62158	
<b>KIR 47</b>	<b>-0.32648</b>	<b>3.29509</b>	
KIR 105	0.52975	3.82484	
<b>KIR 3</b>	<b>-0.26028</b>	<b>3.56456</b>	
<b>KIRIBM</b>	<b>0.84793</b>	<b>4.41250</b>	
<b>KIRI</b>	<b>0.94433</b>	<b>5.35683</b>	
<b>KIRIBM</b>		<b>4.41250</b>	
<b>KIRI RM1</b>	<b>-0.87571</b>	<b>3.53679</b>	
<b>KIRI RM2</b>	<b>-0.03728</b>	<b>3.49951</b>	
<b>KIRI RM3</b>	<b>0.01526</b>	<b>3.51477</b>	



## Time Series of Bench Mark movement relative to the Fixed Deep driven Bench Mark – KIR 1

Precise Differential Levelling - 1992 to 2004 (2006) ◆—◆  
 EDM Height Traversing - commenced 2006 ◆—◆

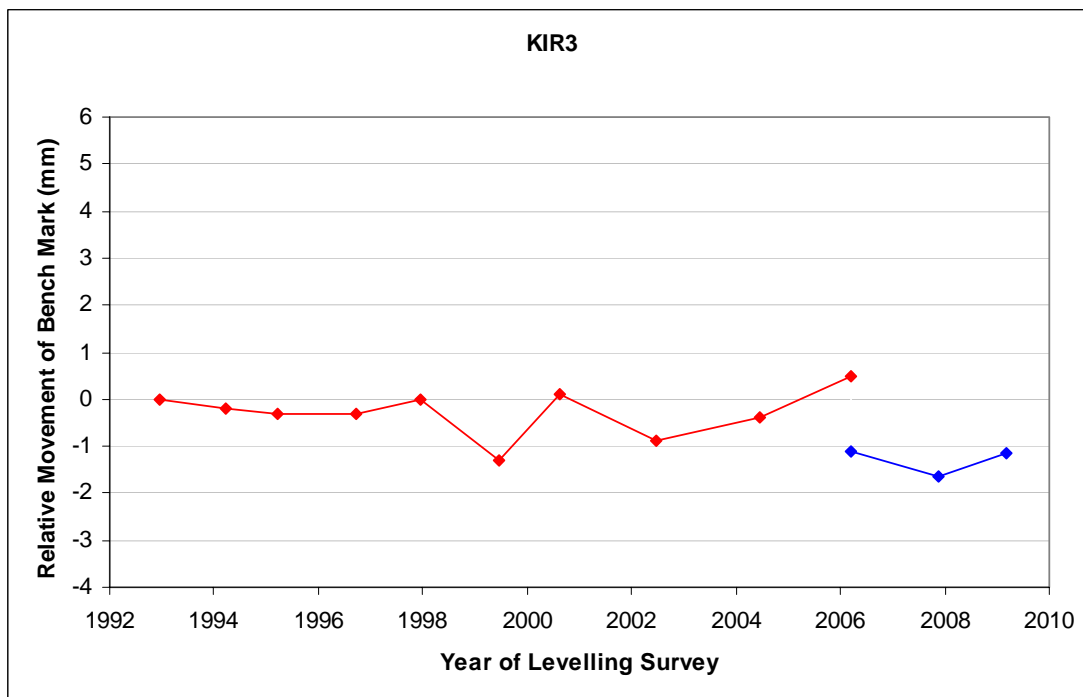
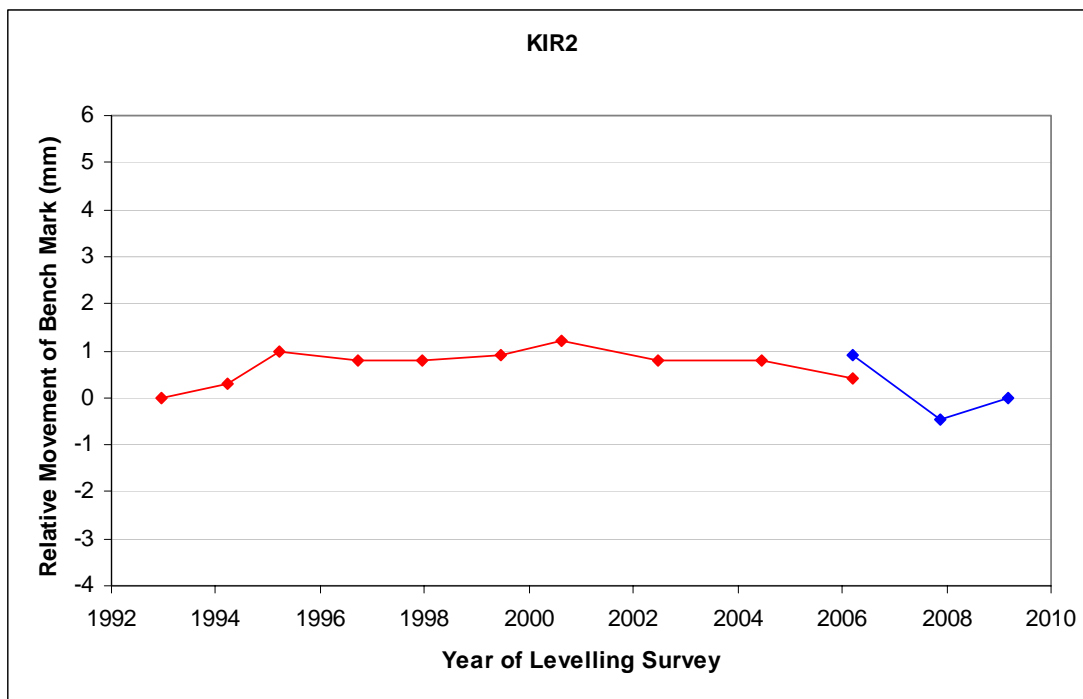

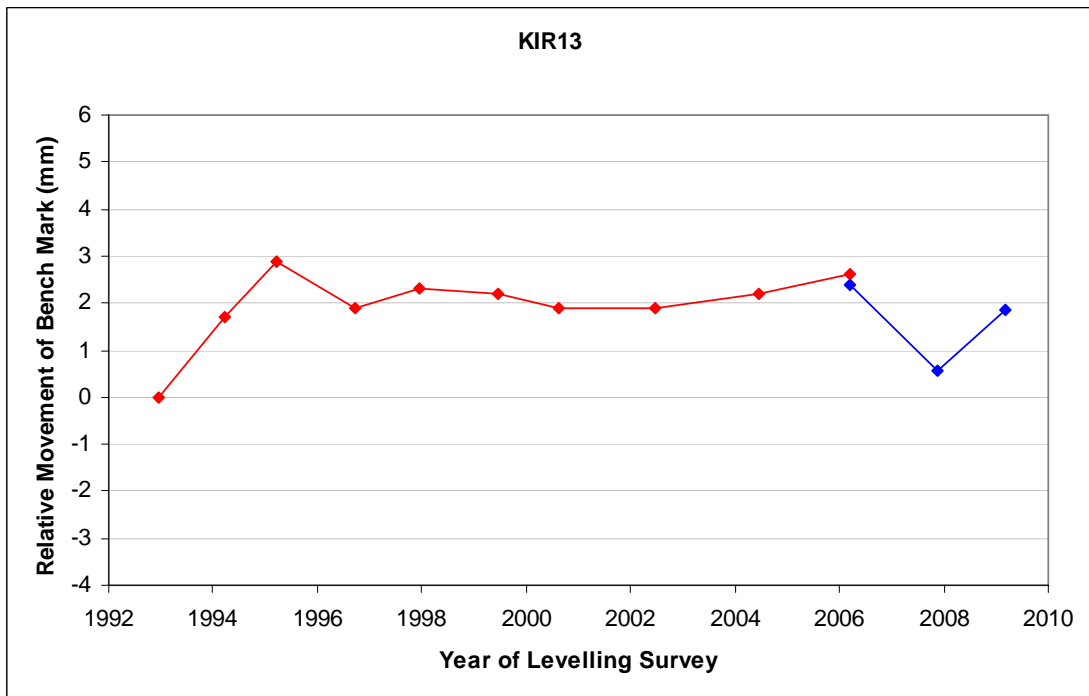
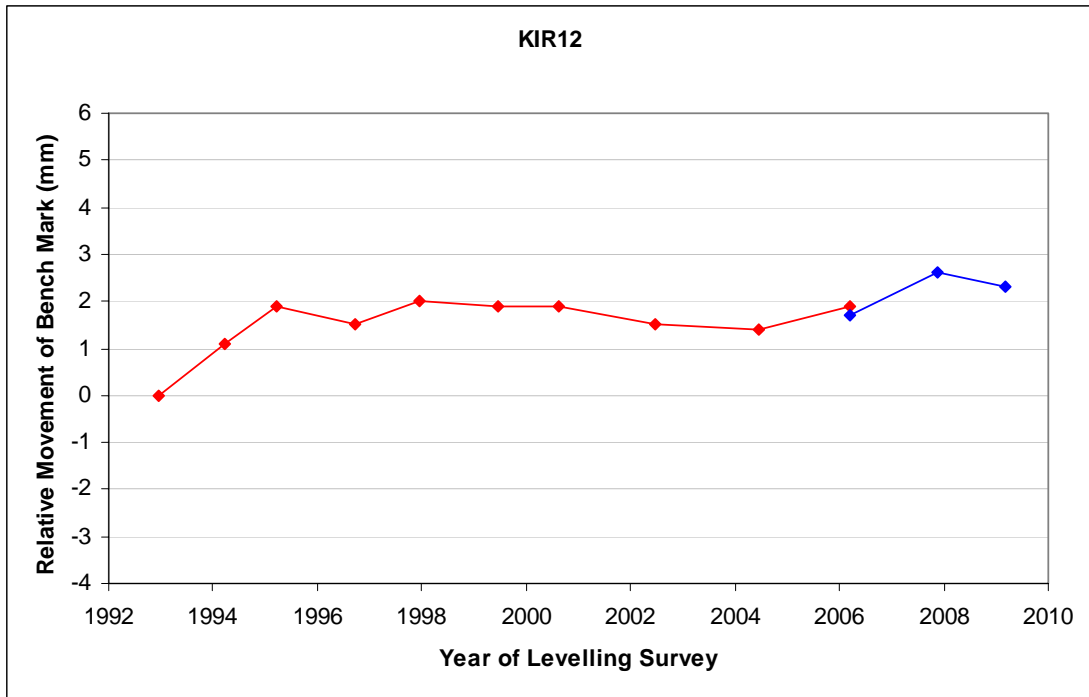

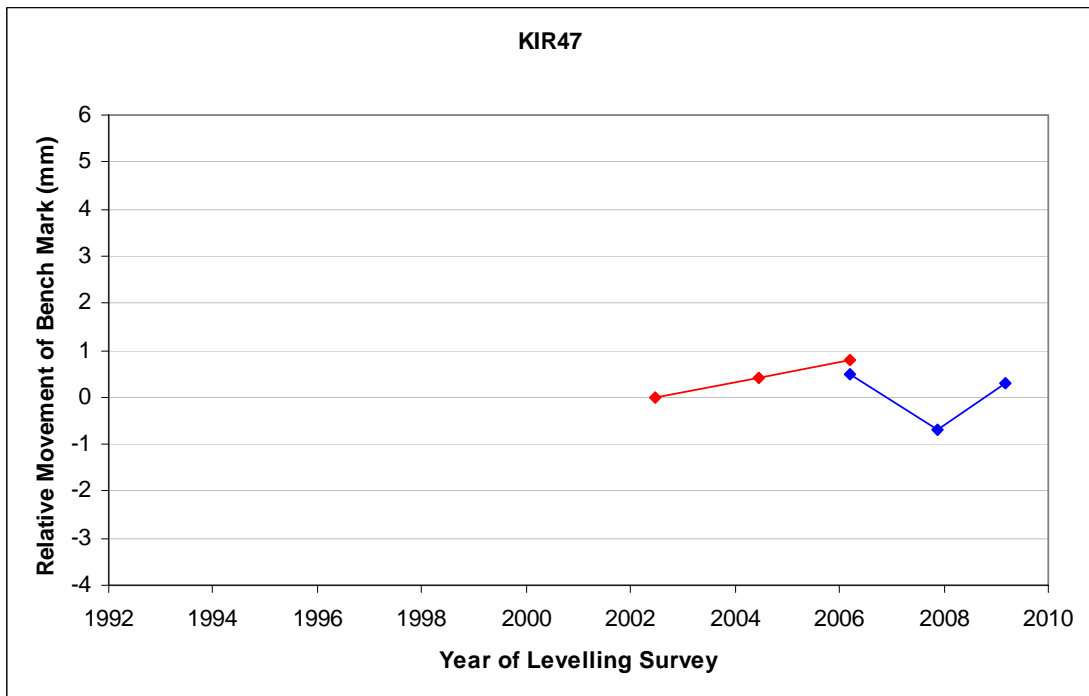
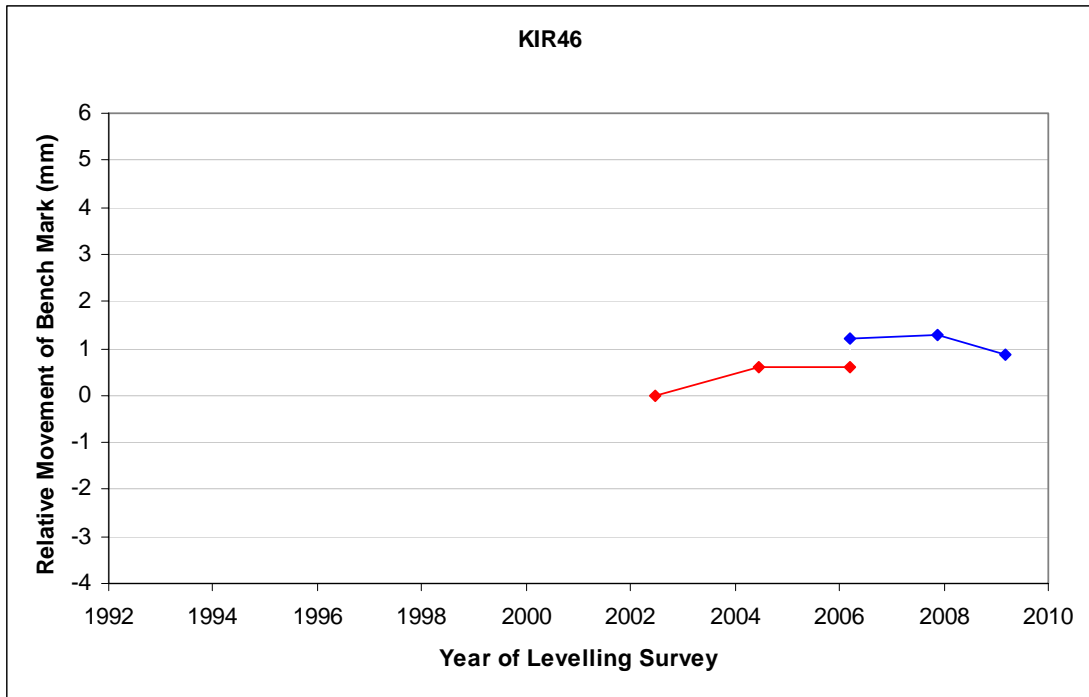

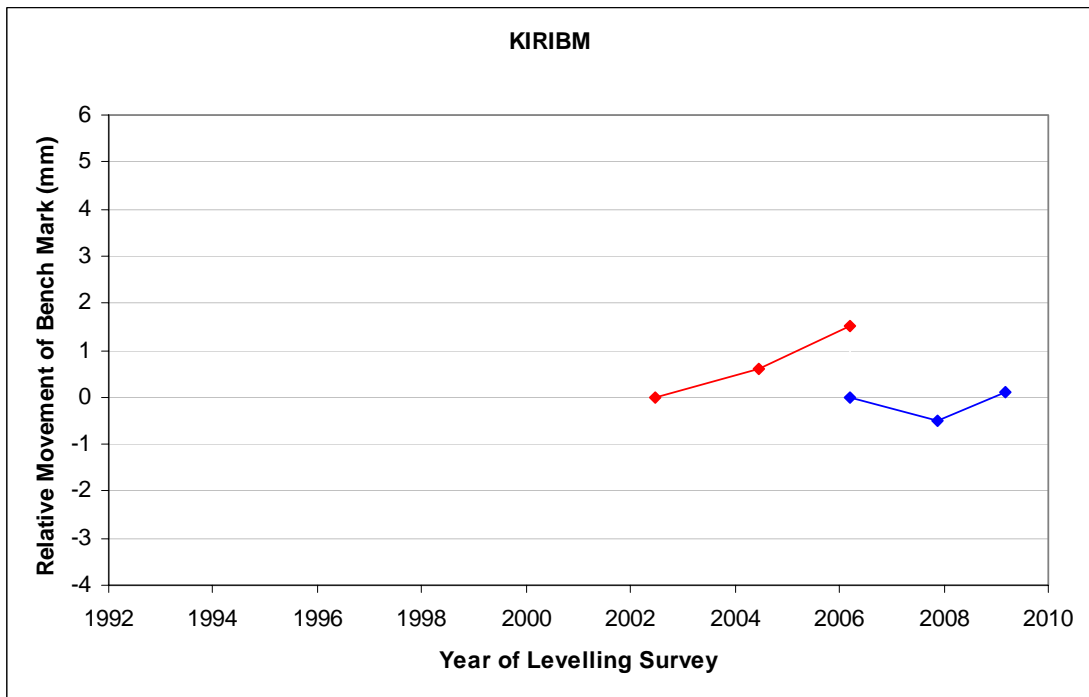
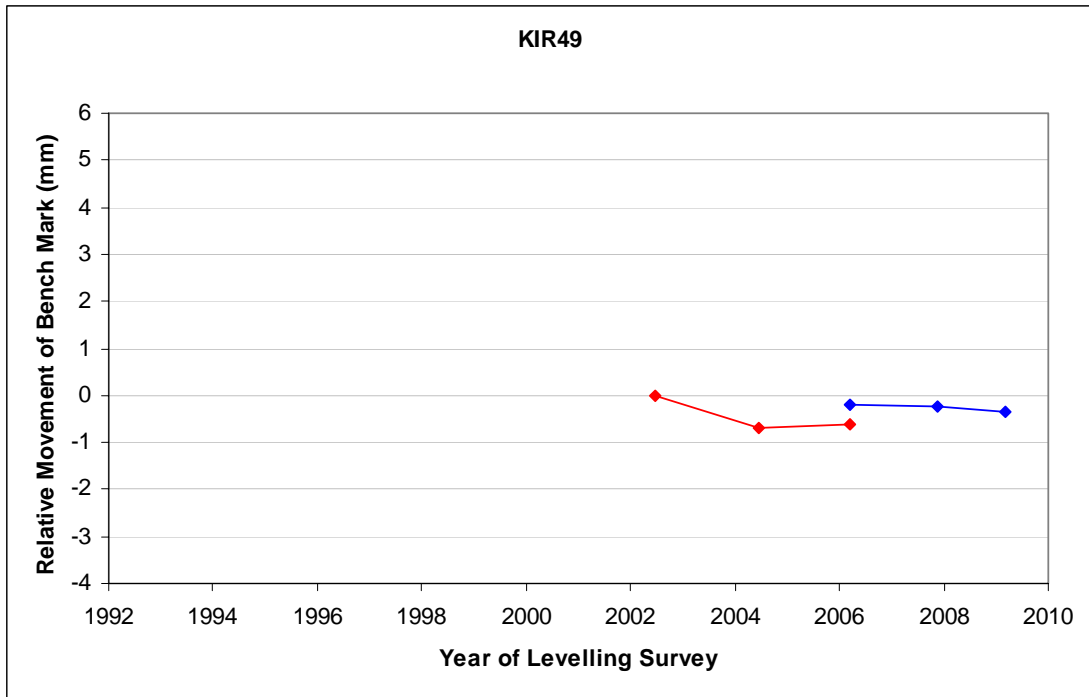

# Deep driven BM and TBM's Locality Diagrams



SOUTH PACIFIC SEA LEVEL  
&  
CLIMATE MONITORING PROJECT



## Survey Bench Mark Record

**Bench Mark Number: KIR1**

Original Bench Mark Established by: National Tidal Centre Australia, Oceanographic Services, Bureau of Meteorology, 25 College Rd, Kent Town, SA. Date: 28-01-92

Existing Bench Mark Established by: Date:

Notes / References: Deep Survey Benchmark  
This survey mark is not in a good locality for GPS occupation.

Country: Kiribati Atoll: Betio  
Island: Tarawa

### Marking and locality sketch

Bench Mark: 6.2m of 19mm diameter stainless steel capped rod driven to refusal.  
Rod sheathed with 50mm diameter PVC pipe, filled with bentonite, for 1.0m. Top of mark 0.2m below ground level.

Locality sketch: Mark approximately 750m from the tide gauge station.

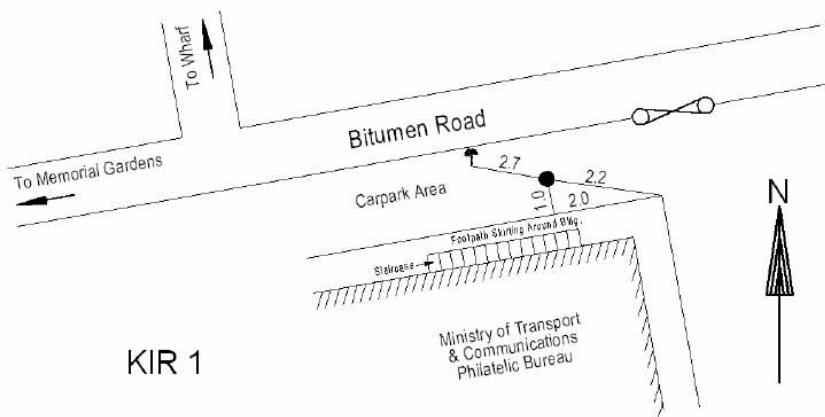

Not to scale Distances in Metres Magnetic bearings

Approved by: Geoscience Australia / SOPAC

Date: April 2006

c:\users\landrick\spslcmp\localitydiagrams\kiribati





**SOUTH PACIFIC SEA LEVEL  
&  
CLIMATE MONITORING PROJECT**



**Survey Bench Mark Record**

**Bench Mark Number: KIR2**

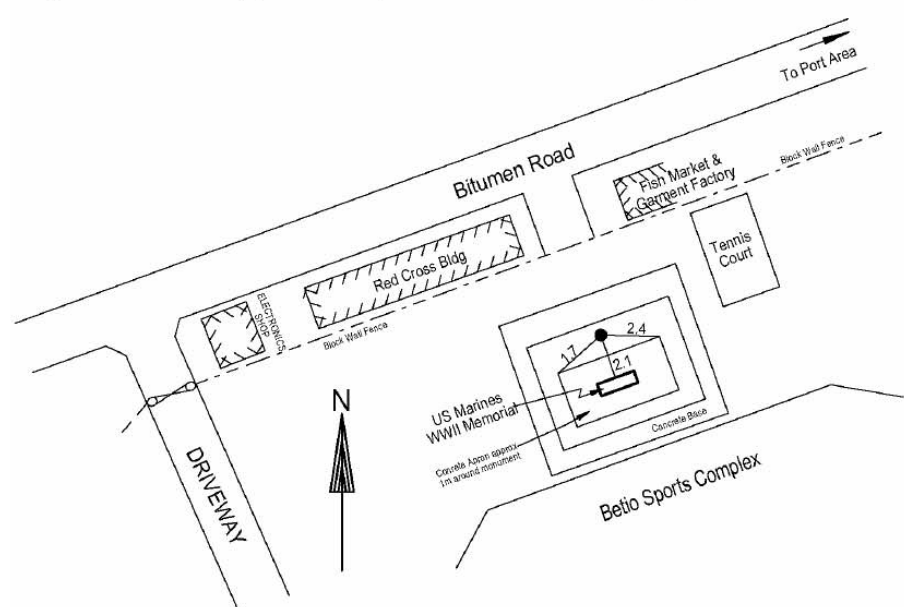
<p><i>Original Bench Mark Established by:</i> National Tidal Centre Australia, Oceanographic Services, Bureau of Meteorology, 25 College Rd, Kent Town, SA.</p>	<p><i>Date:</i> 28-01-92</p>
<p><i>Existing Bench Mark Established by:</i></p>	<p><i>Date:</i></p>
<p><i>Notes / References:</i> Deep Survey Benchmark This survey mark is in a good locality for GPS occupation.</p>	
<p><i>Country:</i> Kiribati <i>Island:</i> Tarawa</p>	<p><i>Atoll:</i> Betio</p>
<p style="text-align: center;"><u>Marking and locality sketch</u></p> <p>Bench Mark: 6.2m of 19mm diameter stainless steel capped rod driven to refusal. Rod sheathed with 50mm diameter PVC pipe, filled with bentonite, for 1.0m. Top of mark 0.3m below ground level.</p> <p>Locality sketch: Mark approximately 1250m from the tide gauge station.</p> 	
<p>Not to scale                      Distances in Metres                      Magnetic bearings</p>	
<p>Approved by: Geoscience Australia / SOPAC                      Date: Dec 2007 c:\users\andrick\spslcmp\localitydiagrams\kiribati</p>	





SOUTH PACIFIC SEA LEVEL  
&  
CLIMATE MONITORING PROJECT



Survey Bench Mark Record

**Bench Mark Number: KIR3**

Original Bench Mark Established by: National Tidal Centre Australia, Oceanographic Services, Bureau of Meteorology, 25 College Rd, Kent Town, SA. Date: 28-01-92

Existing Bench Mark Established by: Date:

Notes / References: Deep Survey Benchmark  
This survey mark is in a good locality for GPS occupation.

Country: Kiribati Atoll: Betio  
Island: Tarawa

Marking and locality sketch

Bench Mark: 6.2m of 19mm diameter stainless steel capped rod driven to refusal.  
Rod sheathed with 50mm diameter PVC pipe, filled with bentonite, for 1.0m. Top of mark 0.2m below ground level.

Locality sketch: Mark approximately 2000m from the tide gauge station.

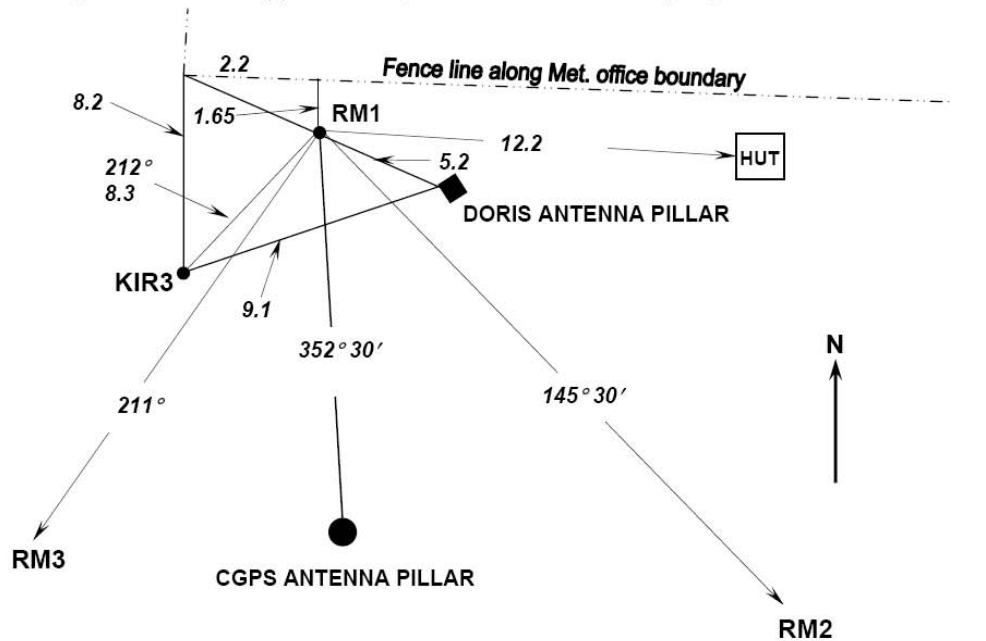

Not to scale Distances in Metres Magnetic bearings

Approved by: Geoscience Australia / SOPAC Date: Dec 2006

c:\users\andrick\spslcmp\localitydiagrams\kiribati





**SOUTH PACIFIC SEA LEVEL  
&  
CLIMATE MONITORING PROJECT**



**Survey Bench Mark Record**

**Bench Mark Number: KIR46**

<i>Original Bench Mark Established by:</i> National Tidal Centre Australia, Oceanographic Services, Bureau of Meteorology, 25 College Rd, Kent Town, SA.	<i>Date:</i> 07-06-02
<i>Existing Bench Mark Established by:</i>	<i>Date:</i>
<i>Notes / References:</i> Deep Survey Benchmark This survey mark is not in a good locality for GPS occupation.	
<i>Country:</i> Kiribati <i>Island:</i> Tarawa	<i>City:</i> Betio
<u>Marking and locality sketch</u>	
Bench Mark: 7.0m of 19mm diameter stainless steel capped rod driven to refusal. Rod sheathed with 50mm diameter PVC pipe, filled with bentonite, for 0.5m. Top of mark 0.1m below ground level.	
Locality sketch: Mark approximately 1000m from the tide gauge station.	
Not to scale	Distances in Metres
Magnetic bearings	
Approved by: Geoscience Australia / SOPAC	Date: April 2006
<small>c:\users\andrick\spslcmp\localitydiagrams\kiribati</small>	





**SOUTH PACIFIC SEA LEVEL  
&  
CLIMATE MONITORING PROJECT**



**Survey Bench Mark Record**

**Bench Mark Number: KIR47**

<i>Original Bench Mark Established by:</i> National Tidal Centre Australia, Oceanographic Services, Bureau of Meteorology, 25 College Rd, Kent Town, SA.	<i>Date:</i> 07-06-02
<i>Existing Bench Mark Established by:</i>	<i>Date:</i>
<i>Notes / References:</i> Deep Survey Benchmark This survey mark is not in a good locality for GPS occupation.	
<i>Country:</i> Kiribati <i>Island:</i> Tarawa	<i>Atoll:</i> Betio
<u>Marking and locality sketch</u>	
Bench Mark: 7.9m of 19mm diameter stainless steel capped rod driven to refusal. Rod sheathed with 50mm diameter PVC pipe, filled with bentonite, for 0.5m. Top of mark 0.1m below ground level.	
Locality sketch: Mark approximately 1700m from the tide gauge station.	
<b>CATHEDRAL</b>	
Not to scale	Distances in Metres
	Magnetic bearings
Approved by: Geoscience Australia / SOPAC	Date: April 2006
<small>c:\users\landrick\spslcmpl\localitydiagrams\kiribati</small>	





**SOUTH PACIFIC SEA LEVEL  
&  
CLIMATE MONITORING PROJECT**



**Survey Bench Mark Record**

**Bench Mark Number: KIR49**

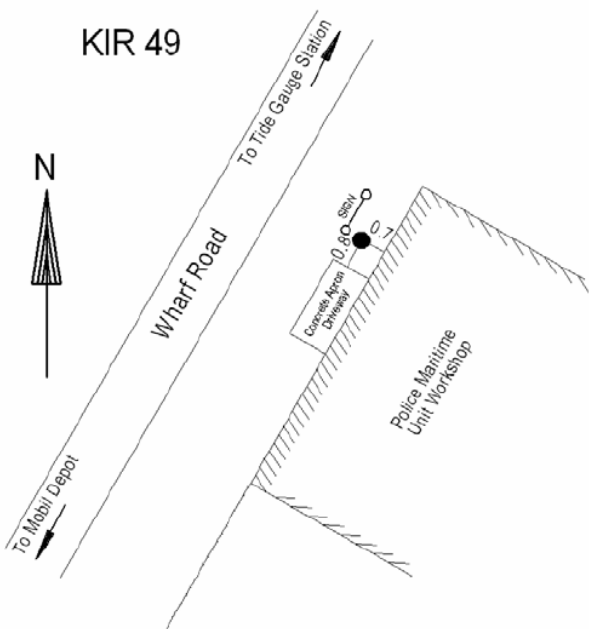
<p><i>Original Bench Mark Established by:</i> National Tidal Centre Australia, Oceanographic Services, Bureau of Meteorology, 25 College Rd, Kent Town, SA.</p>	<p><i>Date:</i> 07-06-02</p>
<p><i>Existing Bench Mark Established by:</i></p>	<p><i>Date:</i></p>
<p><i>Notes / References:</i> Deep Survey Benchmark This survey mark is not in a good locality for GPS occupation.</p>	
<p><i>Country:</i> Kiribati <i>Island:</i> Tarawa</p>	<p><i>Atoll:</i> Betio</p>
<p style="text-align: center;"><u>Marking and locality sketch</u></p> <p>Bench Mark: 2.5m of 19mm diameter stainless steel capped rod driven to refusal. Rod sheathed with 50mm diameter PVC pipe, filled with bentonite, for 0.5m. Top of mark 0.1m below ground level.</p> <p>Locality sketch: Mark approximately 200m from the tide gauge station.</p>  <p>The sketch shows a north-south oriented road labeled 'Wharf Road'. At the top of the road is an arrow pointing north labeled 'To Tide Gauge Station'. At the bottom of the road is an arrow pointing south labeled 'To Mobil Depot'. To the east of the road, there is a building labeled 'Police Maritime Unit Workshop'. A survey mark is indicated by a black dot on the road, with a label 'KIR 49' above it. A scale bar below the sketch shows '0.80' and '0.10' in metres.</p> <p>Not to scale                      Distances in Metres                      Magnetic bearings</p>	
<p>Approved by: Geoscience Australia / SOPAC                      Date: April 2006</p> <p style="text-align: right; font-size: small;">c:\userstandrick\spslcmp\localitydiagrams\kiribati</p>	



COUNTRY: Kiribati	ISLAND: Tarawa ATOLL: Betio	L. D. P. 805 POINT NO. KIR12 & 13
PROJECT: SPSLCMP	SURVEYOR: S. Yates & A Lal	DATE: 20-11-07

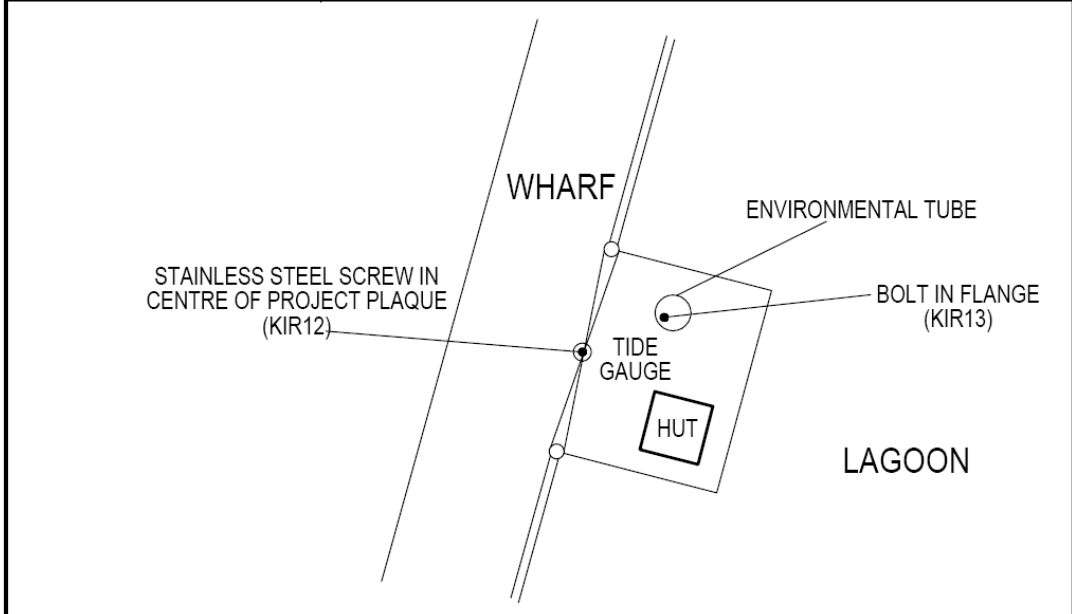

COUNTRY: Kiribati	ISLAND: Tarawa ATOLL: Betio	L. D. P. 806 POINT NO. KIR100
PROJECT: SPSLCMP	SURVEYOR: S. Yates & A Lal	DATE: 20-11-07

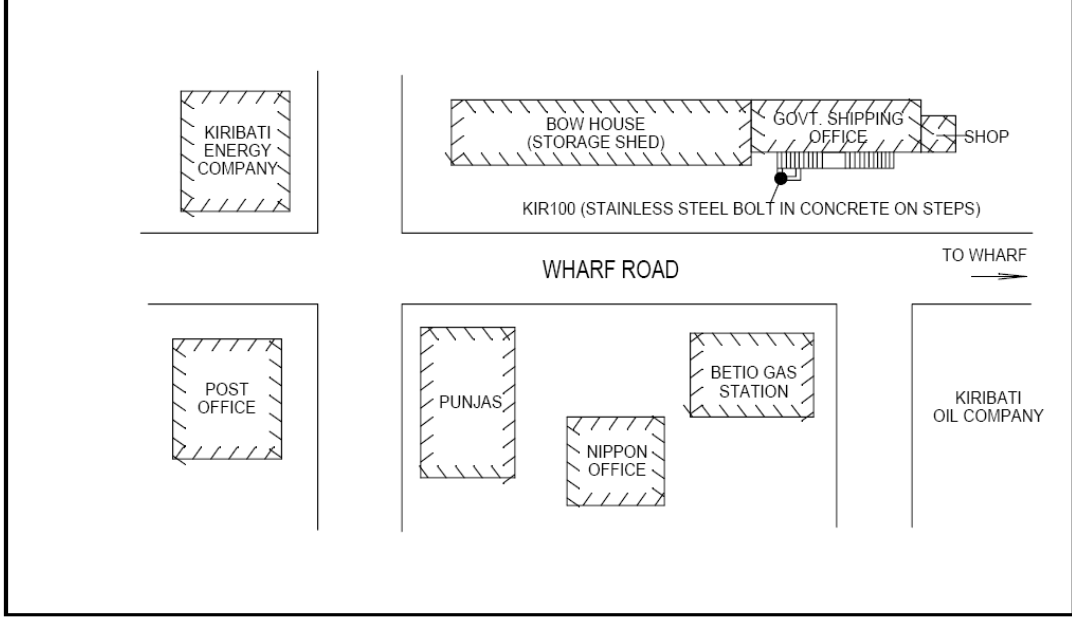

COUNTRY: Kiribati	ISLAND: Tarawa ATOLL: Betio	L. D. P. 807 POINT NO. KIR101
PROJECT: SPSLCMP	SURVEYOR: S. Yates & A Lal	DATE: 20-11-07

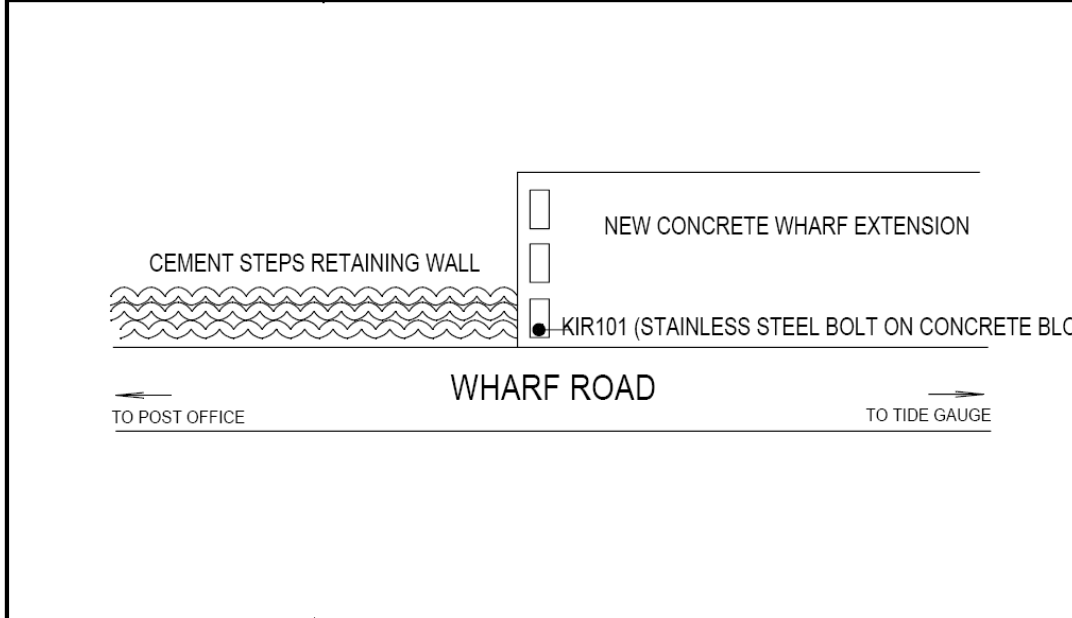

COUNTRY: Kiribati	ISLAND: Tarawa ATOLL: Betio	L. D. P. 808 POINT NO. KIR102
PROJECT: SPSLCMP	SURVEYOR: S. Yates & A Lal	DATE: 20-11-07

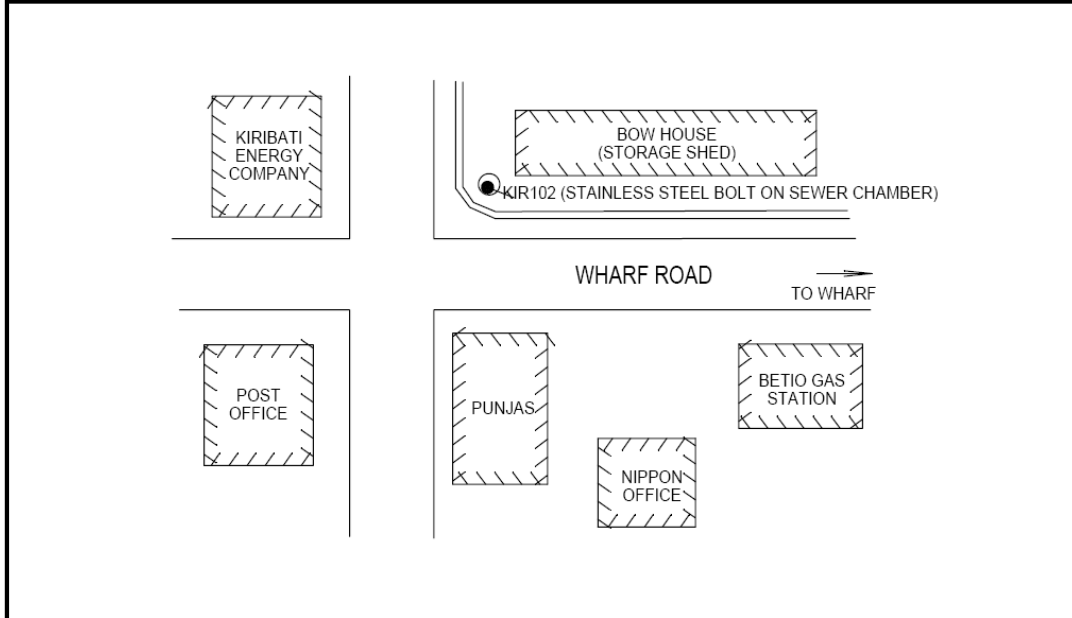

COUNTRY: Kiribati	ISLAND: Tarawa ATOLL: Betio	L. D. P. 809 POINT NO. KIR104
PROJECT: SPSLCMP	SURVEYOR: S. Yates & A Lal	DATE: 20-11-07

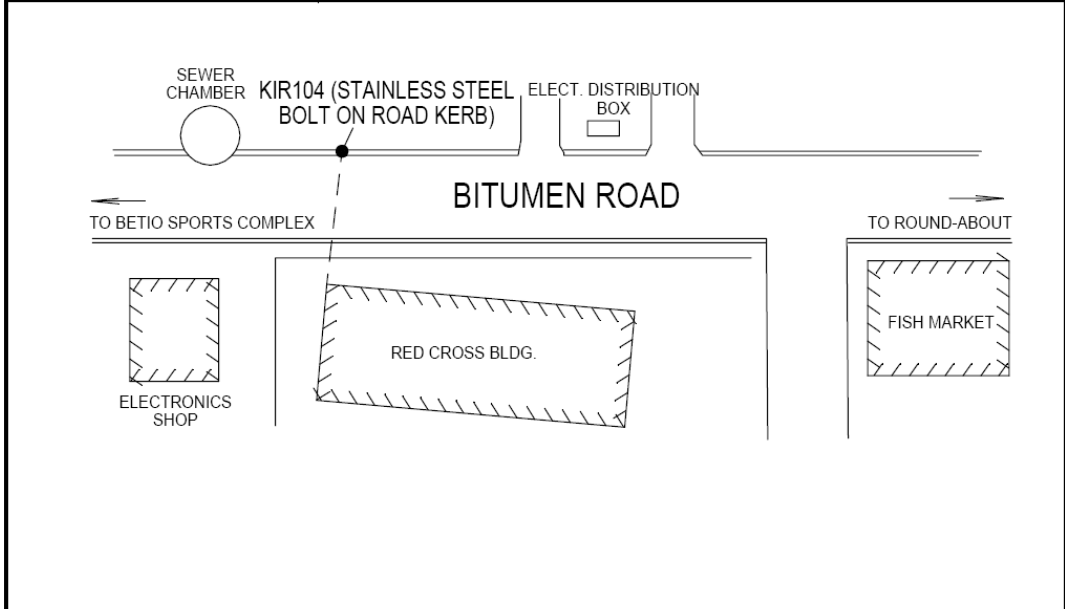

COUNTRY: Kiribati	ISLAND: Tarawa ATOLL: Betio	L. D. P. 810 POINT NO. KIR105
PROJECT: SPSLCMP	SURVEYOR: S. Yates & A Lal	DATE: 20-11-07

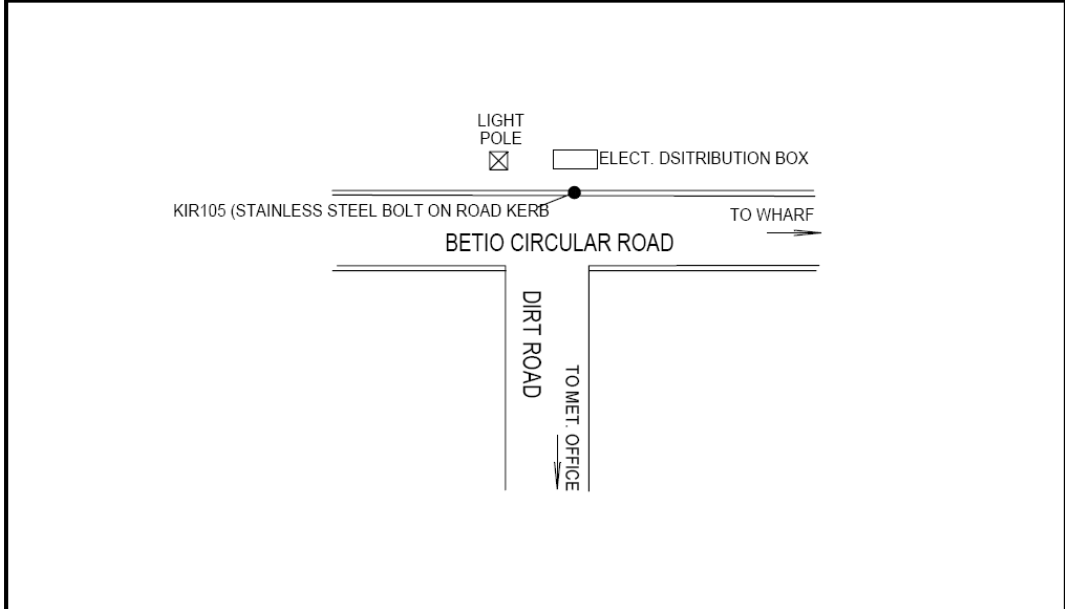

COUNTRY: Kiribati	ISLAND: Tarawa ATOLL: Betio	L. D. P. 811 POINT NO. KIR39
PROJECT: SPSLCMP	SURVEYOR: S. Yates & A Lal	DATE: 20-11-07

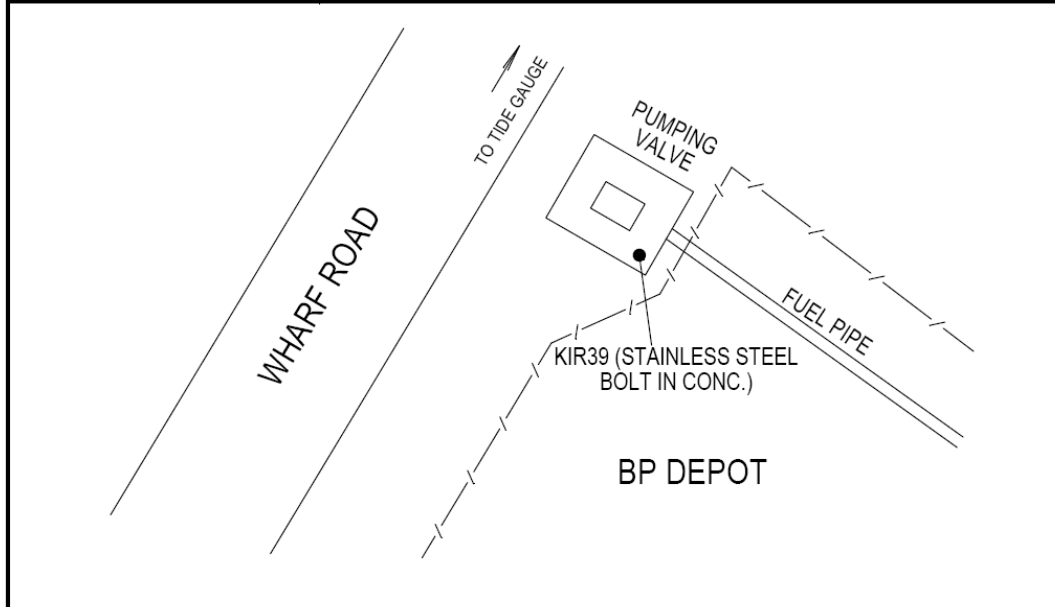

COUNTRY: Kiribati	ISLAND: Tarawa ATOLL: Betio	L. D. P. 812 POINT NO. KIR44
PROJECT: SPSLCMP	SURVEYOR: S. Yates & A Lal	DATE: 20-11-07

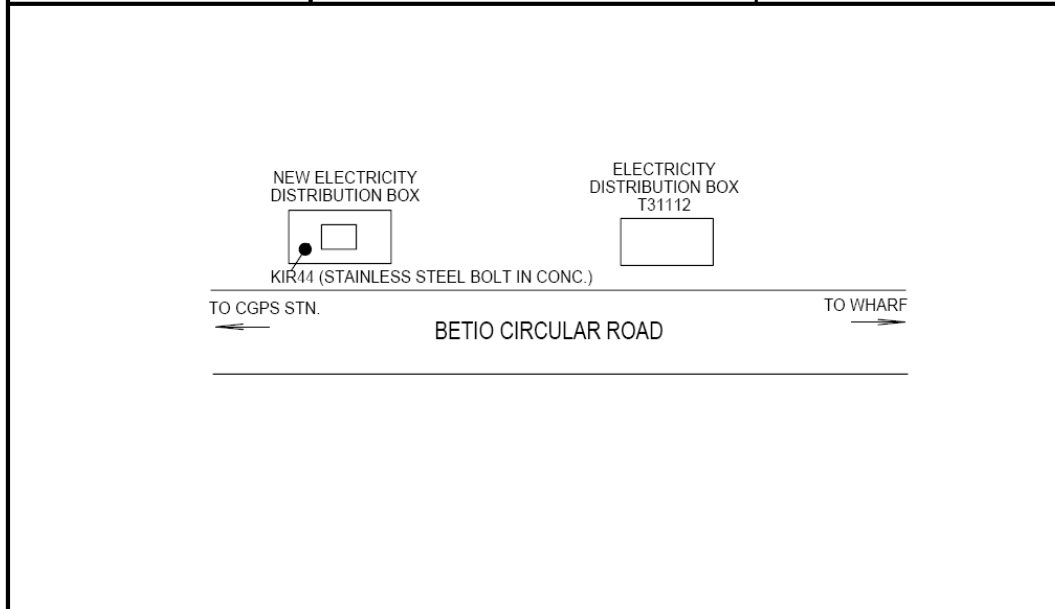

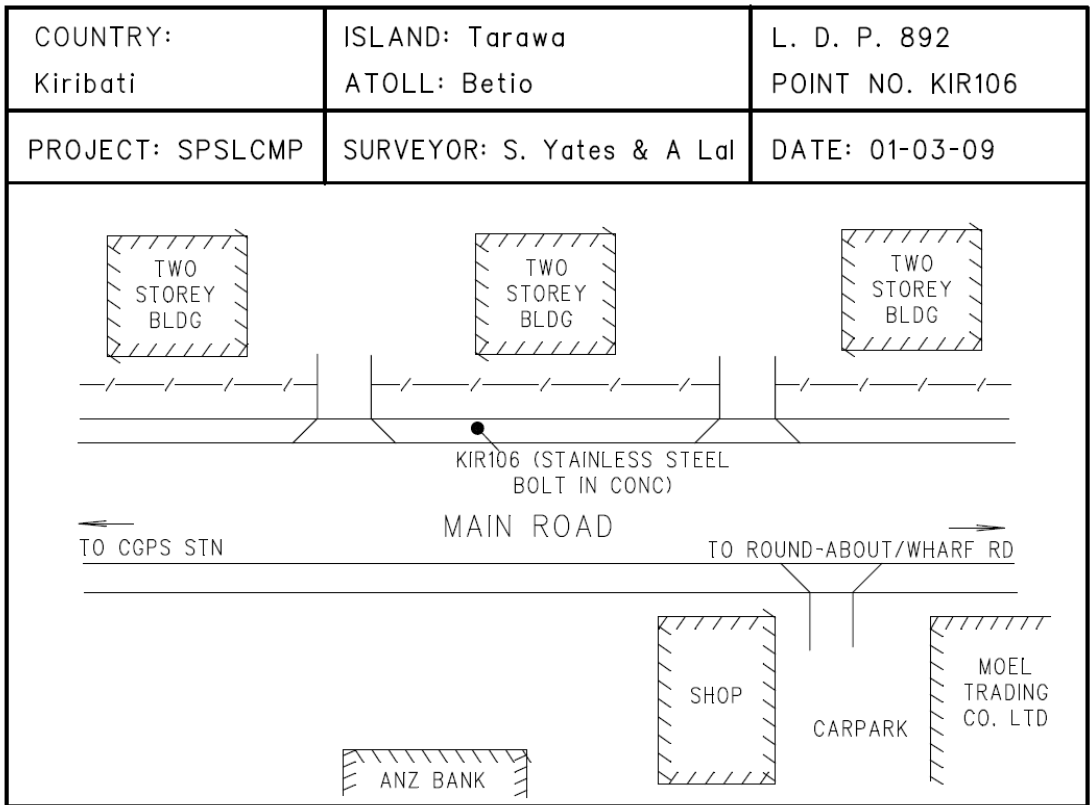

# KIRIBM and KIRI Reference Mark Locality Diagrams

## KIRIBATI CGPS Station, Betio Is. – Reference Marks

### REFERENCE MARKS

All RM's are capped 20 mm stainless steel rods driven to refusal and protected by 150 mm PVC pipe within circular poly carbonate valve boxes. The valve box lids are approximately 50mm below ground level.

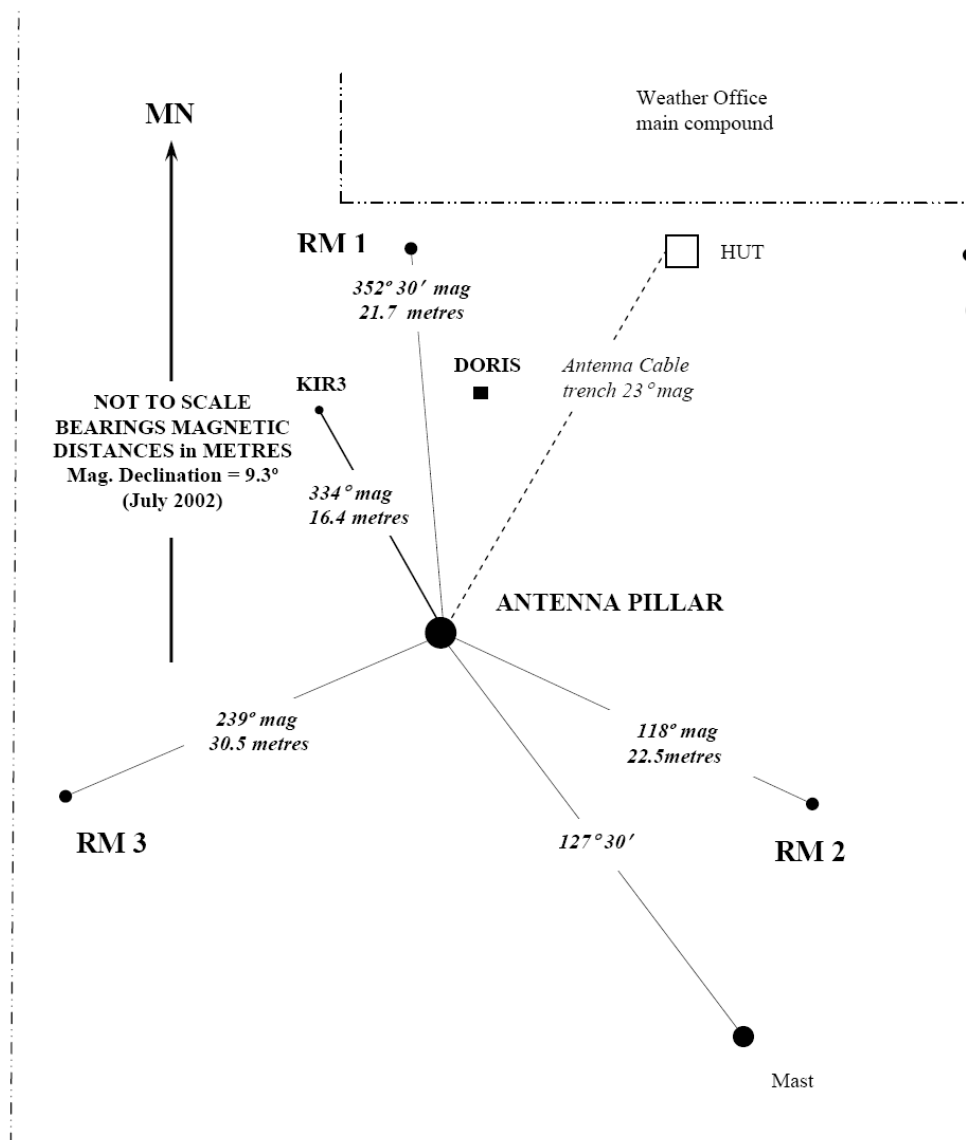

# KIRIBATI CGPS Station, Betio Is. – RM 1

## REFERENCE MARKS

All RM's are capped 20 mm stainless steel rods driven to refusal and protected by 150 mm PVC pipe within circular poly carbonate valve boxes. The valve box lids are approximately 50mm below ground level.

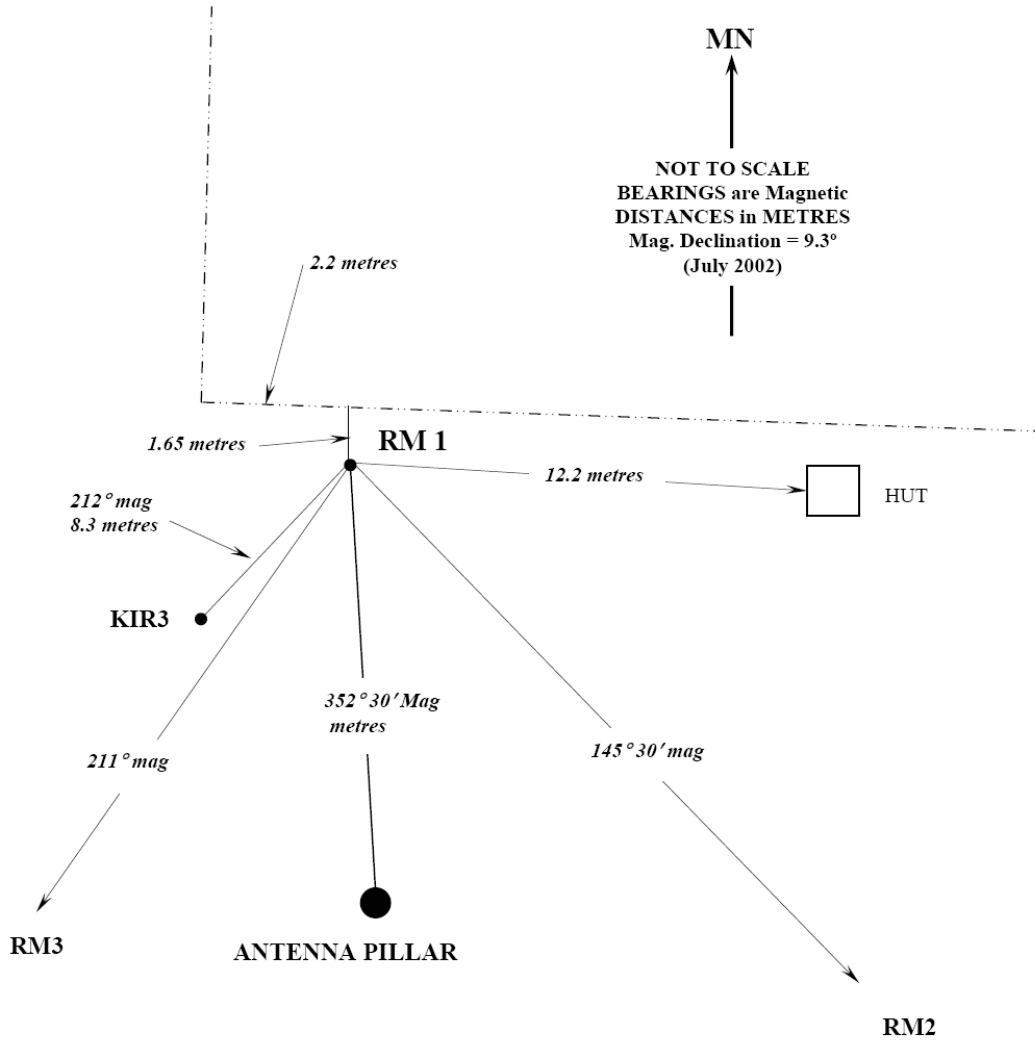

## KIRIBATI CGPS Station, Betio Is. – RM 2

### REFERENCE MARKS

All RM's are capped 20 mm stainless steel rods driven to refusal and protected by 150 mm PVC pipe within circular poly carbonate valve boxes. The valve box lids are approximately 50mm below ground level.

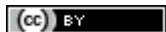
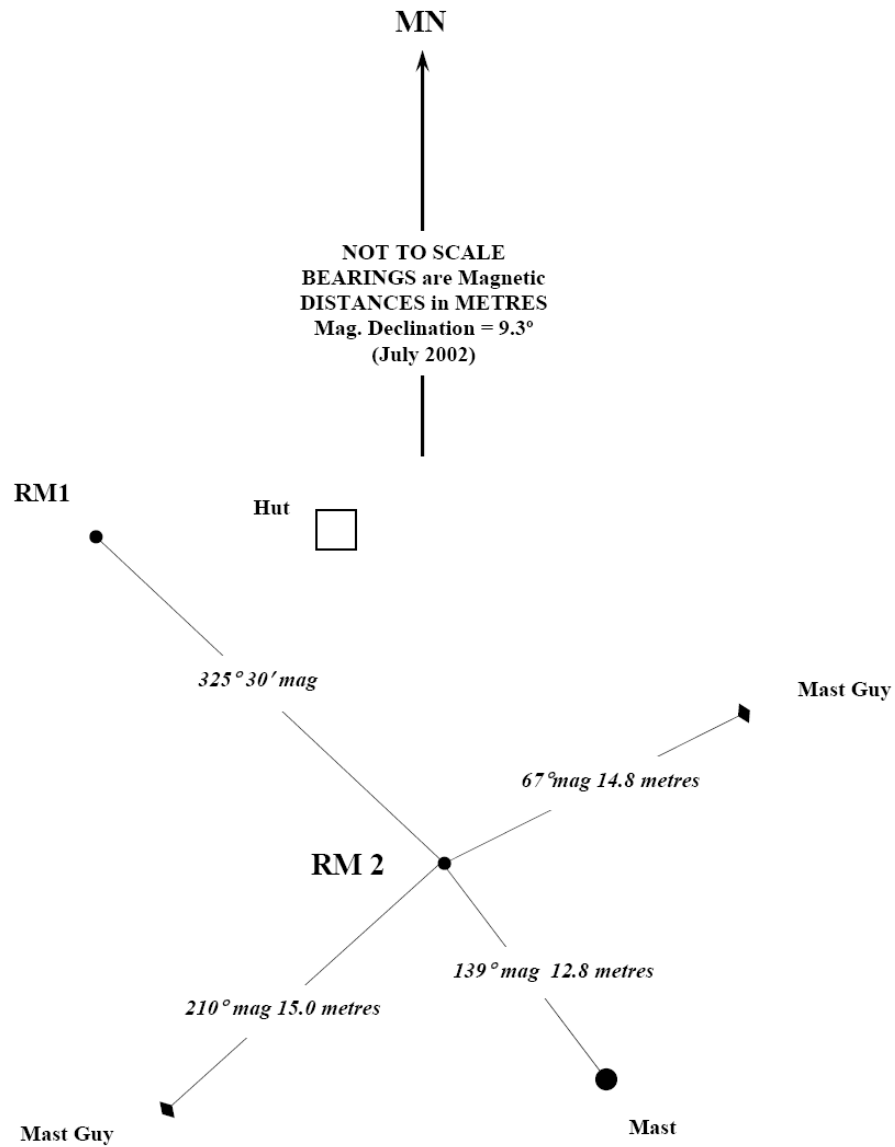

# KIRIBATI CGPS Station, Betio Is. – RM 3

## REFERENCE MARKS

All RM's are capped 20 mm stainless steel rods driven to refusal and protected by 150 mm PVC pipe within circular poly carbonate valve boxes. The valve box lids are approximately 50mm below ground level.

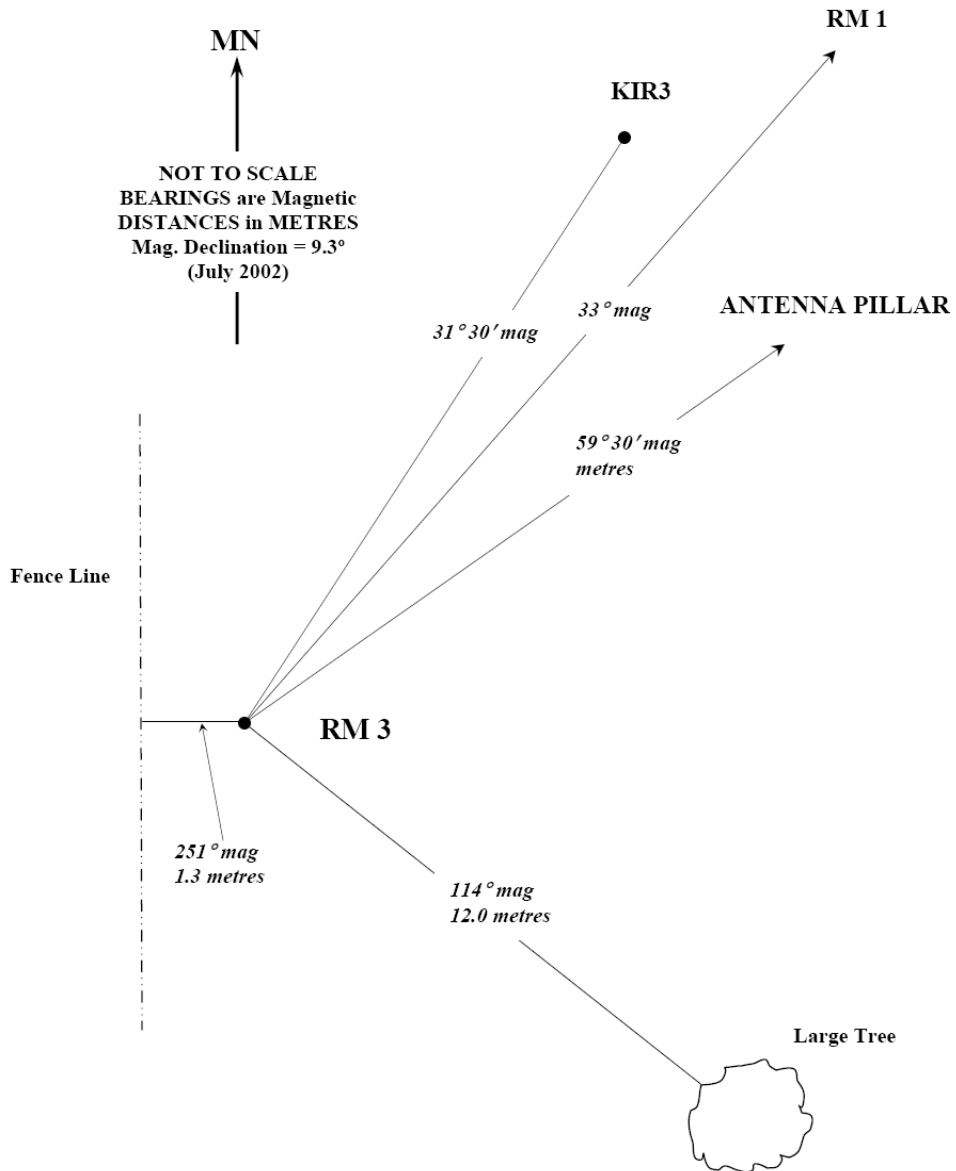

Appendix 6

## Extract from GPS Control Survey, South Tarawa

**GPS CONTROL SURVEY  
SOUTH TARAWA, KIRIBATI  
3-4 October 2000**



*Otintai Hotel, South Tarawa, Kiribati*

**Geraldine Teakle and Litea Biukoto**  
**SOPAC Hazards Assessment Unit**

*October 2000*

*SOPAC Preliminary Report 125*

**Disclaimer**

Opinions expressed in this report are not necessarily those of the SOPAC Secretariat, neither does the mention of any agency, firm or licensed process imply endorsement by SOPAC. The opinions expressed in this report are wholly those of the Authors who will not be made liable for the interpretation, use or misuse of the information herein presented.

## CONTENTS

GOAL .....	3
TASK .....	3
METHODOLOGY.....	3
RESULTS.....	7
TASK STATUS AND FURTHER WORK PLANNED.....	10
REFERENCES.....	10
 ATTACHMENTS	
1 Ground Control Station ID: 7033, Airport Runway.....	11
2 Ground Control Station ID: 7045, Otintai Hotel.....	12
3 Ground Control Station ID: 7057, Betio Pillar .....	13
4 Ground Control Station ID: 7058, Betio Wharf.....	14
5 Ground Control Station ID: 7061, Betio Radio Mast.....	15
6 Ground Control Station ID: KIR12, Betio Wharf NTF Sea-level monitoring plaque	16
7 Notes from Schlencker Mapping Pty Ltd (1998).....	17
8 Notes from National Tidal Facility (1999).....	18
 TABLES	
1 Ground Control Stations.....	4
2 Project Information.....	7
3 Computed Coordinates.....	8
4 Published Coordinates .....	8
5 Differences between Computed & Published Coordinates.....	8
 FIGURE	
1 GPS Ground Control Survey, South Tarawa, Kiribati.....	9

## **GOAL**

A completed building assets GPS survey and fire hazard assessment in South Tarawa, Kiribati.

## **TASK**

Carry out a GPS control survey in South Tarawa, Kiribati.

## **METHODOLOGY**

### ***Field Crew***

Country Counterpart: Erene Nikora, Director of Department of Lands and Survey, Kiribati.  
SOPAC: Geraldine Teakle and Graham Shorten.

### ***Data Processing***

SOPAC: Litea Biukoto and Geraldine Teakle, Hazards Assessment Unit.

### ***Control Survey***

Ground control points recorded by Schlencker Mapping Pty Ltd (1998) and the National Tidal Facility (1999) were surveyed by Geraldine Teakle and Graham Shorten of SOPAC's Hazard Assessment Unit with assistance from Kiribati Director of Department of Lands and Survey, Erene Nikora, on 3<sup>rd</sup> and 4<sup>th</sup> of October 2000.

SOPAC set up the control survey base-station at Betio Pillar, number 7057 of Schlencker Mapping Pty Ltd Ground Control Record (see Attachment 3). A Trimble 12-channel 4600LS Surveyor was setup on point 7057 and was left to log for the duration of the survey. The 8-channel Surveyor was used as a rover and first setup on Betio Wharf, National Tidal Facility (1999) sea level monitoring benchmark, Plaque Number KIR12 (see Attachment 6). The remaining stations used to carry out the SOPAC ground control survey are listed in Table 1, and include Airport Runway (7033), Otintai Hotel (7045), Betio Wharf (7058) and Betio Radio Mast (7061).

It should be noted that the benchmarks on South Tarawa are referenced to the Tarawa Local Grid System and Tarawa WGS84 coordinate.

Seven Parameter Transformation values can be found in Schlencker Mapping Pty Ltd (1998). Attachment 7 contains notes from the latter regarding the control points, transformation parameters and benchmark KIR12. In addition, Attachment 8 (National Tidal Facility 1999) contains reference information on Kiribati benchmarks and other useful information from their precise differential leveling survey conducted in June 1999.

**Table 1. Ground Control Stations**

Station Name	Station Short Name	Locality	Local Start Time 4/10/00	Local End Time 4/10/00	Height (slope or vertical)
Airport Runway	7033	See Attachment 1 (Schlencker Mapping 1998)	1400	1420	976 mm (slope)
Otintai Hotel	7045	See Attachment 2 (Schlencker Mapping 1998) and See Photo 1.	1510	1532	1610 mm (slope)
Betio Pillar (Base Station)	7057	See Attachment 3 (Schlencker Mapping 1998) and See Photo 2.	0917	1610	<ul style="list-style-type: none"> <li>• 163 mm to top of pillar (vertical)</li> <li>• 1292 mm from top of pillar to base of pillar (vertical)</li> <li>• 331 mm from base of pillar to top of roof (vertical)</li> </ul>
Betio Wharf	7058	See Attachment 4 (Schlencker Mapping 1998) and See Photo 3.	1045	1108	950 mm (slope)
Betio Radio Mast	7061	See Attachment 5 (Schlencker Mapping 1998) and See Photo 4.	1125	1205	668 (slope)
Betio Wharf – NTF sea level monitoring plaque	KIR12	See Attachment 6 (National Tidal Facility 1999) and See Photo 5.	1004	1026	2044 mm (vertical)

<sup>1</sup>Slope height is the height measured from the 4600LS hook using the Trimble measuring tape to the center pin of the benchmark or trig point. Vertical height is the height measured from the 4600LS hook using the Trimble measuring vertically to ground.

### **Roads Survey**

A Trimble GeoExplorer II was used to map the roads of South Tarawa, mainly for reference purposes and to be used in the assets and hazard assessment surveys that are planned. Note that on day two (Oct 3<sup>rd</sup>, 2000) the trimble files were corrupted and roads were only recorded for Betio, Bariki and terminated at Otintai Hotel. See map of roads converted to local Tarawa grid coordinates and printed with Tarawa coast in Figure 1 (see Results section).

**Photo 1. Otintai Hotel, Station ID: 7045**



**Photo 2. Betio Pillar (Base Station), Station ID: 7057**



**Photo 3. Betio Wharf, Station ID: 7058**



**Photo 4. Betio Radio Mast, Station ID: 7061**



**Photo 5. Betio Wharf – NTF sea level monitoring plaque, Station ID: KIR12**

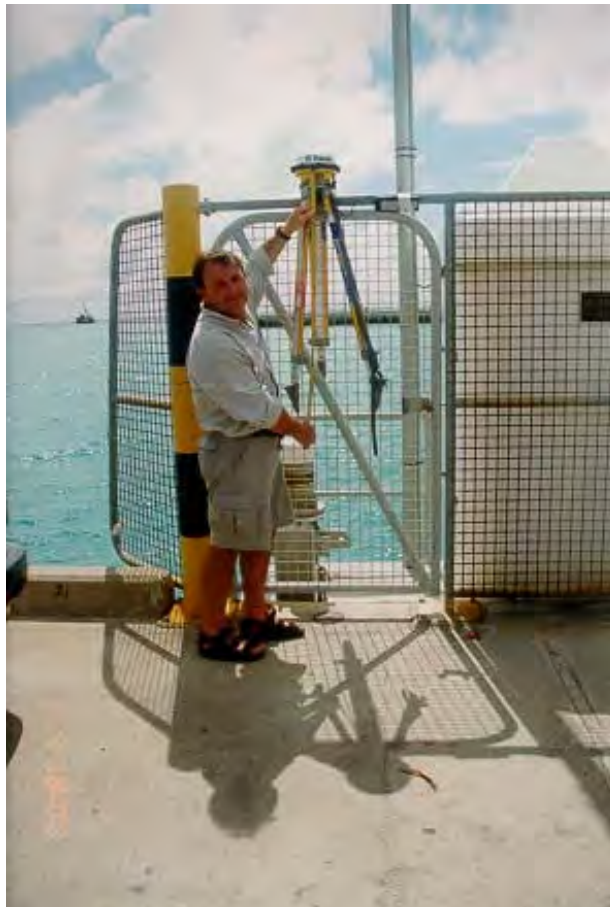

## RESULTS

The Project Information listed in Table 2 below provides an overview of the ground control survey equipment and the parameters required.

**Table 2. Project Information**

Project:	Tarawa
Supervisor:	Geraldine Teakle, Litea Biukoto, Graham Shorten
Date Created:	10/11/00 9:43
Date Last Accessed:	10/11/00 9:47
Project Directory:	C:\GPSURVEY\projects\Tarawa
Antenna Type:	4600LS Internal
Antenna Measurement Method:	Reading from hook using 4600LS tape unless otherwise stated.
Antenna Group:	GPSurvey
Receiver Type:	4600LS
Coordinate System:	Geographic
Zone:	WGS84
Linear Unit:	Meter
Timezone:	Kiribati: GMT + 12:00
Number of Stations:	6
Number of Baselines:	5

### ***Data Processing***

The data acquired in the field survey were processed in two stages:

1. Baseline processing defines the position of a station relative to the known position Betio Trig. A baseline was determined from the Betio Trig to each of the five other stations. The accuracy of a station at this level depends upon the reference position from which Betio Trig was defined.
2. The baseline data were passed through a second process referred to as network adjustment. This process determines the relative precision and quality of the GPS baselines in the survey network. Both coordinates and heights for each station were computed. Comparisons were made between the computed coordinates and heights (Table 3) and the published coordinates and heights (Table 4). The difference between some of the computed and published coordinates and heights (Table 5) is greater than expected and thus some positions may need to be re-surveyed. Station or site locations are shown in Figure 1 below.

**Table 3. Computed coordinates**

Projection Group:	Tarawa Grid System				
Datum Name:	WGS-84				
Linear Units:	Meter				
Station Name	Station ID	Easting	Northing	Ortho. Height	Ellipsoid Height
Betio Pillar (Base Station)	7057	30610.41810	149070.49610	6.65000	36.50953
Airport Runway	7033	53720.28712	152660.42818	4.24876	33.54858
Otintai Hotel	7045	48571.52071	150908.07431	5.21699	34.71402
Betio Wharf	7058	28773.28897	150825.57270	3.17791	33.05337
Betio Radio Mast	7061	27410.89143	149767.02057	4.20233	34.07573
Betio Wharf – NTF sea level monitoring plaque	KIR12	28827.58453	150933.17696	4.13074	34.00644

**Table 4. Published Coordinates**

Projection Group:	Tarawa Grid System			
Datum Name:	WGS-84			
Linear Units:	Meter			
Station Name	Station ID	Easting	Northing	Ortho. Height
Airport Runway	7033	53719.8320	152660.3600	4.2500
Otintai Hotel	7045	48571.5350	150908.0430	3.770
Betio Wharf	7058	28773.2870	15825.5740	3.1600
Betio Radio Mast	7061	27410.687	149767.001	3.86
Betio Wharf – NTF sea level monitoring plaque	KIR12			4.2195

**Table 5. Differences between Computed and Published Coordinates**

Station Name	Station ID	Easting	Northing	Orthometric Height
Airport Runway	7033	0.45512	0.06818	0.00124
Otintai Hotel	7045	0.01429	0.03131	1.44699
Betio Wharf	7058	0.00197	0.0013	0.01791
Betio Radio Mast	7061	0.20443	0.01957	0.34233
Betio Wharf – NTF sea level monitoring plaque	KIR12			0.08876

**Figure 1. GPS Ground Control Survey, South Tarawa, Kiribati.**

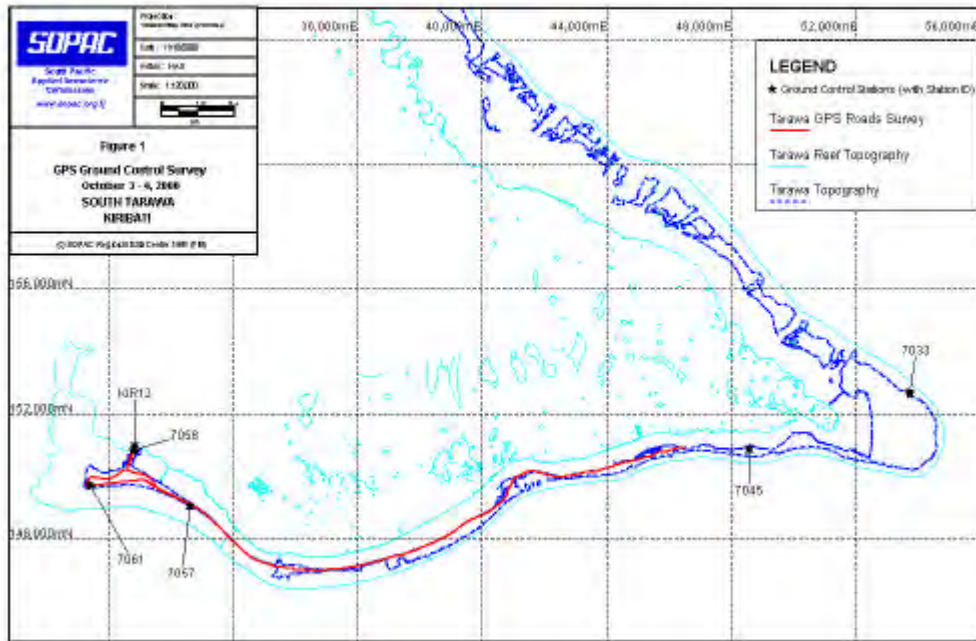

## **TASK STATUS AND FURTHER WORK PLANNED**

A GPS control survey was carried out in South Tarawa, Kiribati on 3<sup>rd</sup> and 4<sup>th</sup> October 2000. The results are listed in Tables 1 – 5 (above). The GPS position of some of the roads in South Tarawa and GPS station positions are shown in Figure 1 (above).

A building assets GPS survey and fire hazard assessment in South Tarawa, Kiribati is planned. In addition, since the difference between some of the computed and published coordinates and heights is greater than expected, some GPS station positions may need to be re-surveyed.

## **REFERENCES**

National Tidal Facility 1999. *Pacific Multi-Country Sea Level and Climate Monitoring Project. Precise Differential Levelling Survey, June 1999, Kiribati*. Prepared for Australian Agency for International Development. October 1999.

Schlencker Mapping Pty Ltd 1998. *Tarawa – Republic of Kiribati, Ground Control report, October 1998 (Revised)*. Zillmere, QLD, Australia.

Appendix 7

## Digital Level – Downloading Procedure

## **Purpose: Perform Line Leveling using the Leica DNA series Digital Level**

**Instrument: DNA10/DNA03**

**There are two models of the Leica DNA series Digital Level; the DNA03 and the DNA10. The DNA03 has the better level accuracy of 0.3mm RMS over 1 Km return leveling run compared to 0.9mm with the DNA10. This is when used with an Invar staff.**

**Further information: Refer to your instrument reference manual.**

### **1. Getting Started**

- a. The DNA level operates on a single NiMH battery. The on switch is located directly below the display screen. The keys on the right hand side of the display screen control the operation of the DNA level.
- b. The INT key allows you to take Intermediate shots
- c. The MODE allows you to set the method of measurement (number of shots etc)
- d. The USER key is a configurable key that is normally set to Code
- e. The PROG key allows you to set up onboard data logging
- f. The DATA key allows you to access recorded information
- g. The SHIFT SET OUT allows you to set out objects at a certain elevation
- h. The SHIFT INV allows you to invert the staff and take levels to the underside of structures
- i. The SHIFT FNC allows you to change create codes and change the auto point incrementing.
- j. SHIFT MENU allows you to change the settings.
- k. The CE will clear the last entry
- l. ESC will take you back one step in any program.

### **2. To Perform Line Leveling**

- a. Select the PROG Key
- b. Select 2. Line Leveling ENTER
- c. 1. Set Job. ENTER
- d. Select NEW and enter job name and then SET.
- e. 2. Set Line. ENTER
- f. *Name* is Line Name. *Meth*: Usually BF method. *PT ID* is point number of Reference Level (Mark that staff is on at the start of the Level run). *HO* is Height of Object (or Reference Level). Press SET

- g. 3. Set Tolerances. Dist Balance: Equal Backlight and Foresight tolerances. Max Dist is maximum length of shot. StafLow is minimum reading on staff allowable. This avoids heat shimmer at base of staff.
- h. By Selecting VALUE you can set the values for the above Tolerances. SET
- i. 4. Start. A check list of the current settings is displayed. OK ENTER
- j. The arrow is on B so take your Backlight first. Focus on leveled staff on Reference Level and press the red measure button below the focus knob. The arrow will now be pointing to F for foresight.
- k. Press the INT key for Intermediate shots. When intermediate shots have been completed press ESC key to return to the Foresight screen.
- l. Take your Foresight to your next change point and then reposition your DNA level ready for the next Backlight and series of intermediate shots.
- m. Record your Backlight and then take your intermediate shots.
- n. Repeat the above process until you are ready to take your final Foresight onto a mark of known height. This can be your starting point (Reference Level) or a different mark of known level/
- o. To finish the survey select Quit. Turn off the level. The data is automatically saved as you go.

### **3. Line Adjustment: For in field Leveling Line Reduction**

- a. Select your Job, Line and method of Misclose adjustment. CONT
- b. Select your Control points i.e. start and end point.
- c. Select RUN to perform adjustment. The adjust points are now displayed.
- d. Select OK to exit.

### **4. Check and Adjust: Used for checking calibration of the DNA Level.**

Appendix 8

## Map Series (Sheets 1-11) Benchmark Locations